

**ZOJE**

**ZJ5781**

**D-series**

**Electronic button hole sewing machine**

**Insturction manual and parts book**

## I. 使用时的注意事项/IMPORTANT SAFETY INSTRUCTION

- 1) 没有往油盒加油时，请绝对不要运转缝纫机。
- 2) 缝制结束之后，请清扫旋梭、切刀部的灰尘和线绒。并确认油量是否充足。
- 3) 使用启动踏板时，缝纫机启动后请把踏板返回到原来的位置否则会连续缝制。
- 4) 本缝纫机装有安全开关，当缝纫机头放倒时，不让缝纫机运转。  
要运转缝纫机时，请把缝纫机头正确地放置到台板上之后，再打开电源开关。

- 1) Never operate the machine unless the oiling tank has been properly lubricated.
- 2) Be sure to remove any dust from the hook or bobbin thread cutting knife section at the end of the day, and check the amount of oil remaining.
- 3) Be sure to return the activating pedal to the home position after the machine has started to run.
- 4) A safety switch is installed so that this sewing machine can't be operated in the state that the machine head is tilted. When operating this sewing machine, turn the power switch ON after setting the sewing machine to the bed base properly.

## II. 规格/SPECIFICATIONS

### 1. 机种/Subclass

5780D 系列高速电子平头锁眼机有以下系列机型。

5780D Series Computer-controlled high-speed lockstitch Straight Button-holing Industrial Sewing Machines has the subclass machines below.

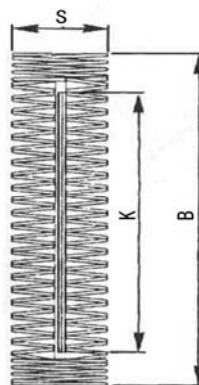
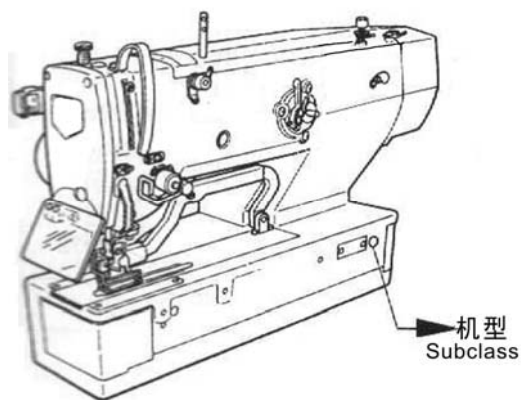

机种 Subclass	套结宽幅(S) Width of noose	切刀尺寸 Size of cutter	缝制长度(B) Sewing length	主要用途 Major application
5780DS-V3 5781DS-V3	最大 6mm The maximum 6mm	6.4~31.8mm (1/4"~1-1/4)	最大 41mm The maximum 41mm	缝制衬衣、衬衫、工作服、女装等棉布扣眼 Buttonholing of cloth such as men's shirts, blouses, work uniforms
5780DK-V3 5781DK-V3	最大 6mm The maximum 6mm	6.4~31.8mm (1/4"~1-1/4)	最大 41mm The maximum 41mm	T 恤、POLO 衫等针织料纽扣 T-shirt polo shirt knitted material
5780DL-V3 5781DL-V3	最大 6mm The maximum 6mm	6.4~31.8mm (1/4"~1-1/4)	最大 120mm The maximum 120mm	缝制衬衣、衬衫、工作服、女装等棉布纽扣 Buttonholing of cloth such as men's shirts, blouses, work uniforms

## 2. 规格/Specifications

名称	规格
套结宽幅	标准 5mm
缝纫速度	标准 3600rpm (最高 4200rpm)
使用机针	DP×5 #11J ~ #14J
针杆行程	34.6mm
旋梭	DP 型 全自动旋转供油旋梭
压脚上升量	6mm (可任意设定) 最大 17mm (逆转抬压脚时)
抬压脚驱动方式	脉冲马达式 (1 个踏板 • 2 个踏板)
绕线功能	机头内置式 (在机器驱动中可绕线)
送布驱动方式	脉冲马达式
摆针驱动方式	脉冲马达式
切刀驱动方式	脉冲马达式
面线张力机能	电磁铁张力方式通过控制面板操作可对各部位进行数据设定 (平行部、套件部张力)
缝迹形状	角型、放射型、圆型 (控制面板选择) 等 30 种
记忆花样数	500 个花样
外形尺寸	机床宽度 200mm、高度 360mm、长度 570mm
机头重量	55Kg
电源	单向 220V





## 2. 规格/Specifications

Name of Controller	specifications
Width	5mm (Min: 0.05mm)
Sewing Speed	Standard 3600rpm Max 4200rpm
Needles	DP×5 # 11J ~ # 14J
Stroke of Needle Bar	34.6mm
Shuttle	Type DP, All-auto Rotation Oil-supply Shuttle
Presser Height	6mm (Customized Setting) Max 17mm(Reverse pressure lifting foot )
Winding	Build-in Type (winding at machine running)
Cloth-feeding Driving Device	Pulse Motor
Swing Needle Driving	Pulse Motor
Knife Driving Device	Pulse Motor
Upper-thread Tension Function	Solenoid Tension Method User can set the data at control panel to adjust each part (Parallel Part, Doubling Part Tension)
Stitch Form	Angle, Radial, Round (Selected at Control Panel) and other 30 types
Patterns in Memory	500 Patterns
Size	Width 200mm、Height 360mm、Length 570mm
Head Weight	55Kg
Motor used	single phase 220V

### 3. 标准缝衣形状一览表/Standard sewing shape list

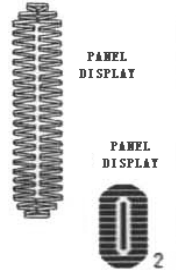
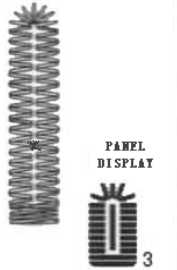
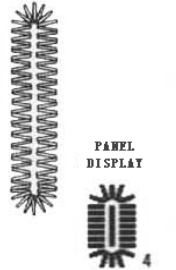
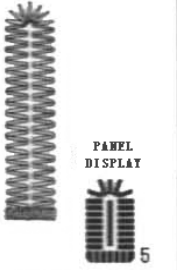
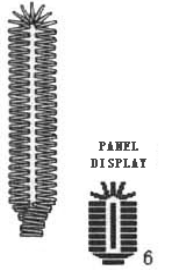
1. 角型	2. 圆形	3. 辐射角型	4. 辐射型	5. 辐射直角加固型	6. 辐射锥型加固型
 液晶显示 1	 液晶显示 2	 液晶显示 3	 液晶显示 4	 液晶显示 5	 液晶显示 6
7. 圆头扣眼角型	8. 圆头扣眼辐射型	9. 圆头扣眼直线加固型	10. 圆头扣眼锥型加固型	11. 半月型	12. 圆形型
 液晶显示 7	 液晶显示 8	 液晶显示 9	 液晶显示 10	 液晶显示 11	 液晶显示 12
13. 半月角型	14. 半月直线加固型	15. 半月锥型加固型	16. 圆头扣眼半月型	17. 圆头扣眼圆形型	18. 角辐射型
 液晶显示 13	 液晶显示 14	 液晶显示 15	 液晶显示 16	 液晶显示 17	 液晶显示 18
19. 角半月型	20. 角圆形	21. 角直线型加固型	22. 角锥型加固型	23. 辐射半月型	24. 辐射圆形型
 液晶显示 19	 液晶显示 20	 液晶显示 21	 液晶显示 22	 液晶显示 23	 液晶显示 24
25. 半月辐射型	26. 半月圆形	27. 加固缝	28. 加固右切断	29. 加固左切断	30. 加固中央切断
 液晶显示 25	 液晶显示 26	 液晶显示 27	 液晶显示 28	 液晶显示 29	 液晶显示 30

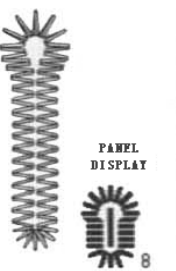
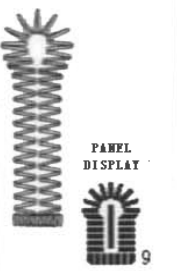
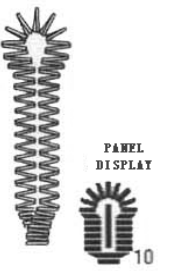
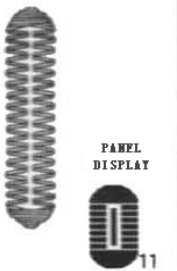
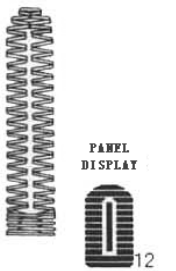
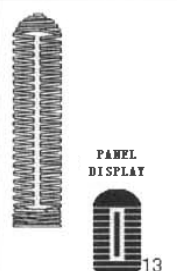
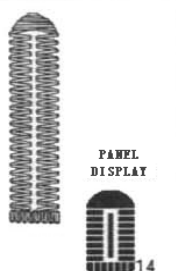
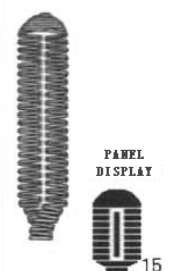
### 3. 标准缝衣形状一览表/Standard sewing shape list

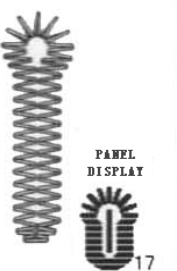
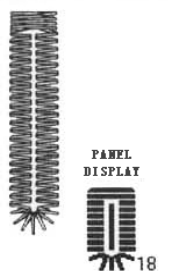
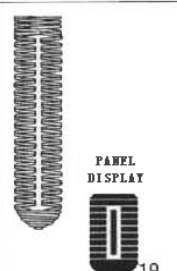
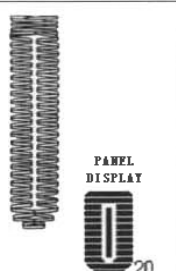
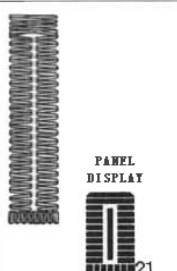
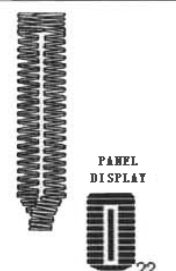
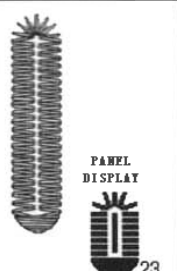
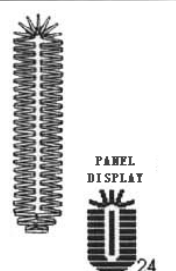
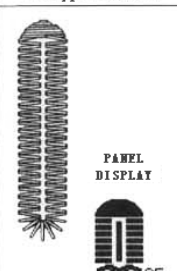
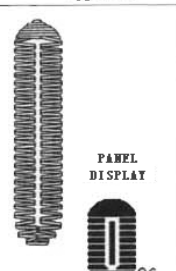
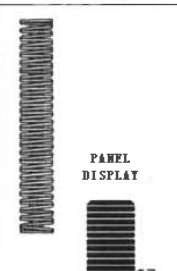
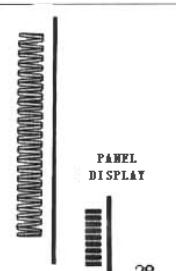
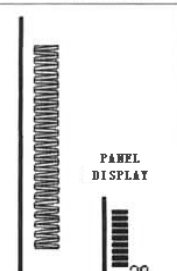
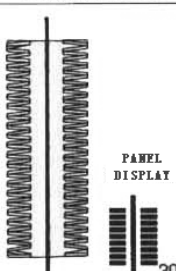
<p>1. Square type</p>  <p>PANEL DISPLAY</p> <p>1</p>	<p>2. Round type</p>  <p>PANEL DISPLAY</p> <p>2</p>	<p>3. Radial square type</p>  <p>PANEL DISPLAY</p> <p>3</p>	<p>4. Radial type</p>  <p>PANEL DISPLAY</p> <p>4</p>	<p>5. Radial straight bar-tacking type</p>  <p>PANEL DISPLAY</p> <p>5</p>	<p>6. Radial taper bar-tacking type</p>  <p>PANEL DISPLAY</p> <p>6</p>
<p>7. Eyelet square type</p>  <p>PANEL DISPLAY</p> <p>7</p>	<p>8. Eyelet radial type</p>  <p>PANEL DISPLAY</p> <p>8</p>	<p>9. eyelet straight bar-tacking type</p>  <p>PANEL DISPLAY</p> <p>9</p>	<p>10. Eyelet taper bar-tacking type</p>  <p>PANEL DISPLAY</p> <p>10</p>	<p>11. Semilunar type</p>  <p>PANEL DISPLAY</p> <p>11</p>	<p>12. Round square type</p>  <p>PANEL DISPLAY</p> <p>12</p>
<p>13. Semilunar square type</p>  <p>PANEL DISPLAY</p> <p>13</p>	<p>14. Semilunar taper bar-tacking type</p>  <p>PANEL DISPLAY</p> <p>14</p>	<p>15. Semilunar taper bar-tacking type</p>  <p>PANEL DISPLAY</p> <p>15</p>	<p>16. Eyelet semilunar type</p>  <p>PANEL DISPLAY</p> <p>16</p>	<p>17. Eyelet round type</p>  <p>PANEL DISPLAY</p> <p>17</p>	<p>18. Square radial type</p>  <p>PANEL DISPLAY</p> <p>18</p>
<p>19. Square semilunar type</p>  <p>PANEL DISPLAY</p> <p>19</p>	<p>20. Square round type</p>  <p>PANEL DISPLAY</p> <p>20</p>	<p>21. Square straight bar-tacking type</p>  <p>PANEL DISPLAY</p> <p>21</p>	<p>22. Square taper bar-tacking type</p>  <p>PANEL DISPLAY</p> <p>22</p>	<p>23. Radial semilunar type</p>  <p>PANEL DISPLAY</p> <p>23</p>	<p>24. Radial round type</p>  <p>PANEL DISPLAY</p> <p>24</p>
<p>25. Semilunar radial type</p>  <p>PANEL DISPLAY</p> <p>25</p>	<p>26. Semilunar round type</p>  <p>PANEL DISPLAY</p> <p>26</p>	<p>27. Bar-tacking</p>  <p>PANEL DISPLAY</p> <p>27</p>	<p>28. Bar-tacking, right cut</p>  <p>PANEL DISPLAY</p> <p>28</p>	<p>29. Bar-tacking, left cut</p>  <p>PANEL DISPLAY</p> <p>29</p>	<p>30. Bar-tacking, center cut</p>  <p>PANEL DISPLAY</p> <p>30</p>

## 4. 构成

5780D 系列由以下部分所构成：

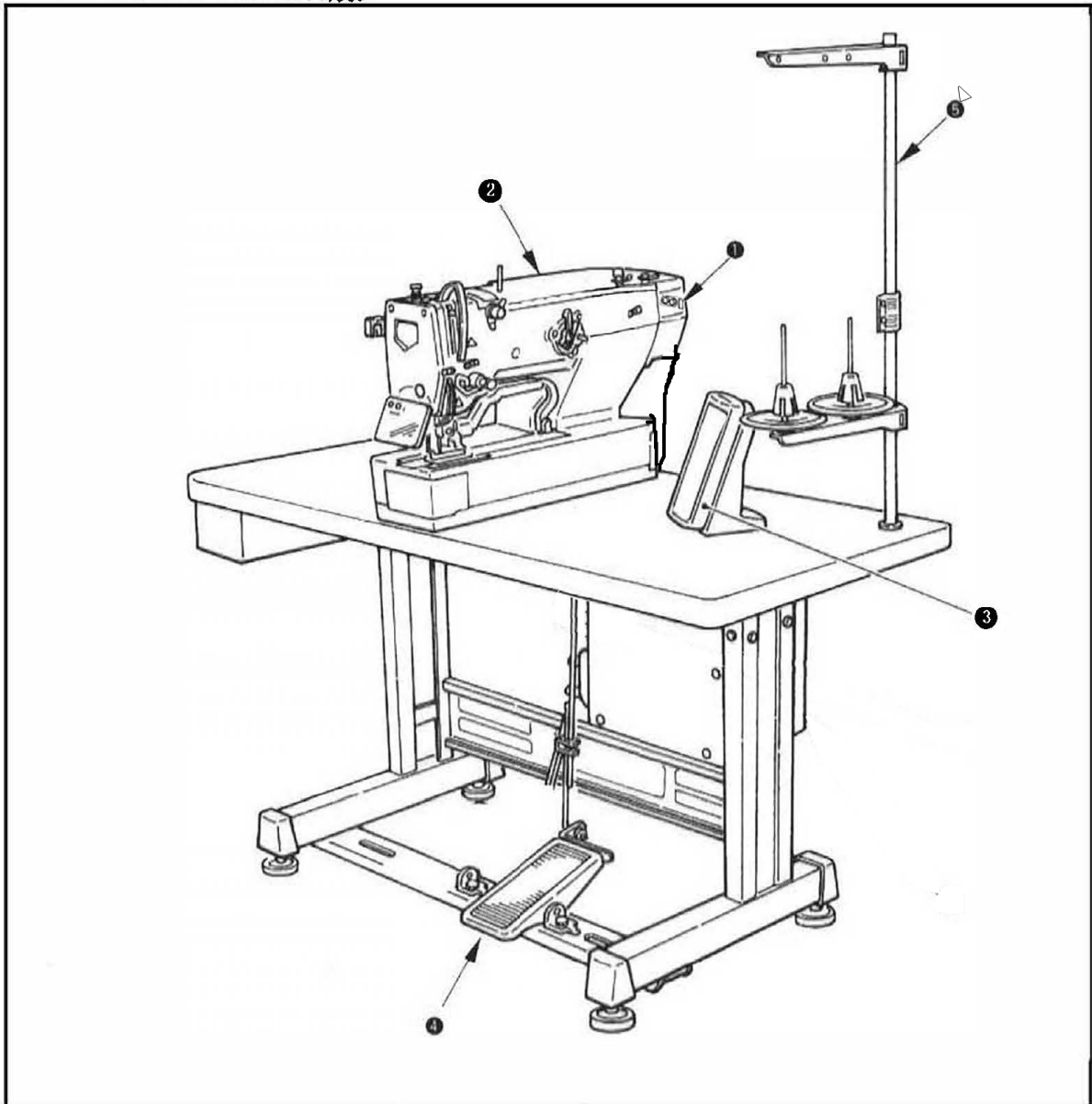

①	电源 ON/OFF 开关	Power ON/OFF switch
②	缝纫机机头 (5780B 系列)	Machine head (5780B Series)
③	操作板	Operation panel
④	抬压脚、启动踏板	Presser lifting pedal and start pedal
⑤	线架装置	Thread stand device

### III. 安装/INSTALLATION

★危险： 搬运缝纫机时，请至少 2 人以上进行。

★WARNING: To prevent possible accidents caused by fall of the sewing machine, perform the work by two persons or more when the machine is moved.

#### (1) 板的安装/Set-up of the table

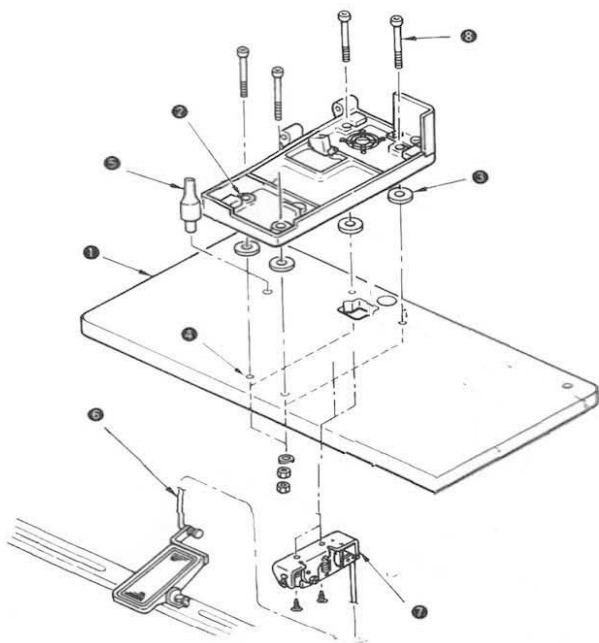

- 1) 把底座锁紧螺钉⑩（4个）穿过底座⑥。
- 2) 把减震橡胶安装到台板的底座固定孔⑥（4处），然后固定底座⑥。
- 3) 把机头支撑杆③固定到台板②上。
- 4) 把缝纫机主机放到台板②上后，把踏板和踏板开关④和附件的连接杆⑦连接起来。

►注意：请调整踏板位置，不让连接杆⑦和其他部件相碰

- 1) Pass four bed base fixed screws (10) through bed base ⑥.
- 2) Set rubber cushions (5) to holes (6) and then fix on the base.
- 3) Fix head support bar ③ on table ②.
- 4) After placing the sewing machine main unit on bed base ②, connect pedal ④ to pedal switch ④, connecting rods ⑦ which have been supplied as accessories.

►CAUTION : Adjust the positions of the pedals so that connecting rod ⑦ and other parts collide

(3) 缝纫机主体的安装/ Installing the sewing machine main unit .

▶注意：搬运缝纫机时，请一定2人以上进行。

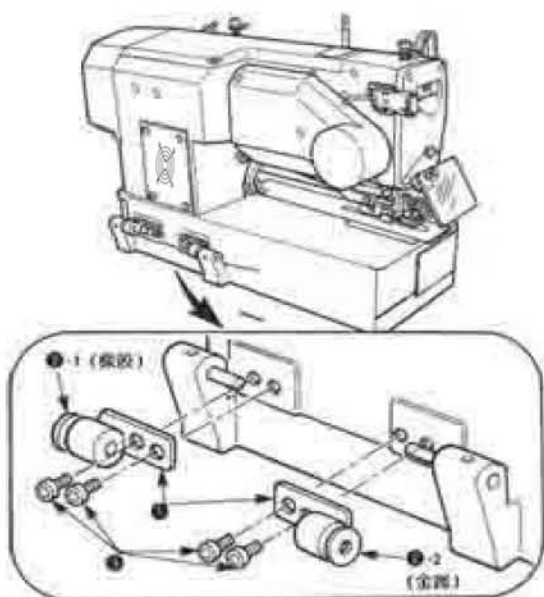

▶注意：不要把橡胶铰链和金属铰链安装反了，否则放倒缝纫机时会有危险。

▶CAUTION: To prevent possible accidents caused by the tail of the sewing machine, perform the work by two personal or more when the machine is moved.

CAUTION: Place hinge plates ❶ and shaft bearings ❷ in two places on the head base and fix the hinge plates to the machine head with setscrew ❸ in two places.



#### (4) 缝纫机的放倒方法/ Tilting the sewing machine head

★危险：放倒或抬起缝纫机时，请注意不要被缝纫机夹住手指。  
为了防止突然的起动造成的事故，请关掉电源之后再进行操作。

放倒缝纫机时，请轻轻地放倒，让缝纫机被机头支撑杆①支撑住。



►注意：

1. 放倒缝纫机之前，请先确认台板上是否装有机头支撑杆①。
2. 为防止缝纫机突然倒下，请一定把缝纫机放到水平的地方，再放倒缝纫机。

★WARNING : When tilting /raising the sewing machine head, perform the work so as not to allow your fingers to be caught in the machine, to avoid possible accidents caused by abrupt start of the machine, turn OFF the power to the machine before starting the work.

When tilting the sewing machine head, tilt quietly the sewing machine until head support bar①comes in.

►CAUTION:

1. Make sure that sewing machine head support bar ① is placed on the table before tilting the sewing machine
2. To protect-fall-down, be sure to tilt the sewing machine in a level place.

### (5) 安全开关的连接/Connecting the safety switch connector

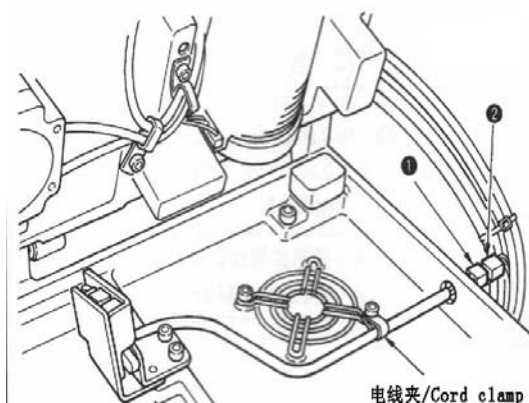

打开机头后罩，把安全开关的插口①连接到机头后端电路板 JP7②上，再重新罩上后罩。

After open the machine cover, connecting safety switch connector ① with connect ② located on the PCB which is on the back of the machine.

### (6) 挡油板的安装/Installing the hook oil shield plate

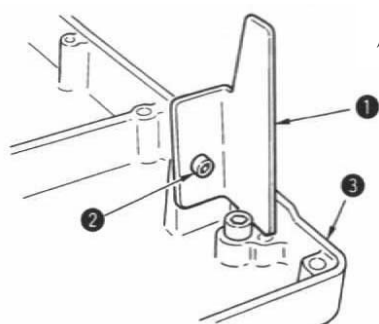

用固定螺钉②把挡油板①安装到底座③上。

►注意：放倒缝纫机或抬起缝纫机时，请注意不要碰到挡油板①。

Install hook oil shield plate ① onto bed base ③ with setscrew ②.

►CAUTION : Fixes the sewing machine so that it does not come in contact with hook oil shield plate ① when raising/tilting the sewing machine.

(7) 操作板的安装/ Installing the operation panel

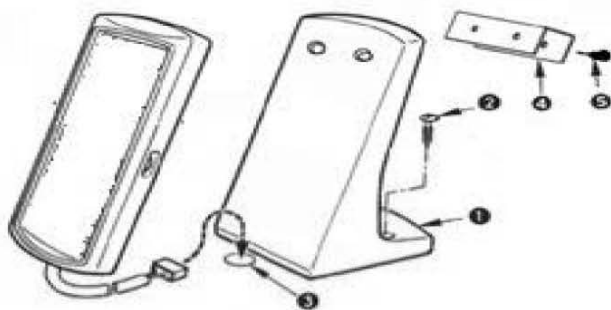

用木螺钉②把操作板座①固定到台板上, 再把电缆穿过台板孔③。

Install hook oil shield plate  
① onto bed base③ with setscrew  
②.

(8) 电缆的处理/ Managing the cord

请一边慢慢地放倒缝纫机, 一边确认电缆没有被勾住。

►注意: 放倒缝纫机时, 请确认机头支撑杆安装在台板上。

Slowly tilting the sewing machine, check that the cords are not forcibly pulled.

►CAUTION : When you tilt the sewing machine, make sure that the sewing machine head support bar② is placed on the table.

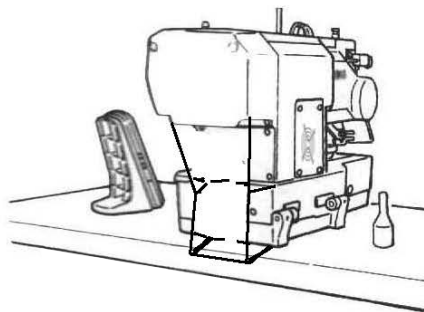
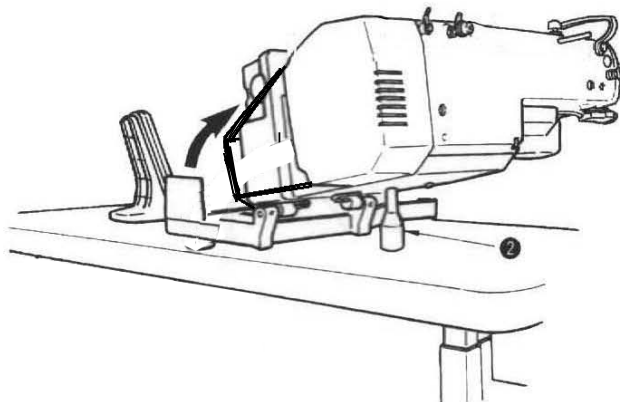

### (9) 眼睛防护罩的安装/Installing the eye protection cover

★危险：为了保护断针飞起弄伤眼睛，请一定安装起来。

请一定安装眼睛防护罩①后使用缝纫机。

★WARNING : Be sure to attach this cover to protect the eyes from the disperse of needle breakage

Be sure to install and use eye protection cover ① and use the sewing machine.

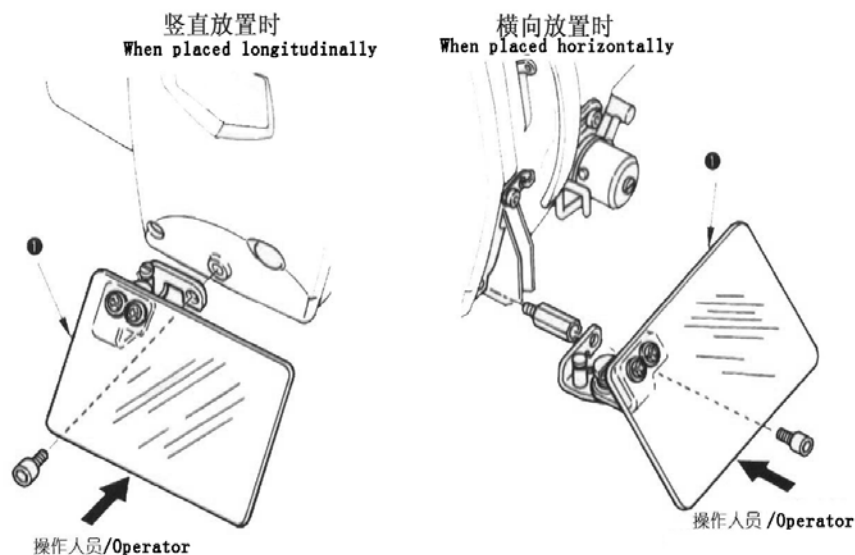

### (10) 急停开关的固定/Fixing the temporary stop switch

出货时，暂停开关为 A 的状态，请拧松固定螺钉，更为 B 状态，然后用附件的固定螺钉②和固定螺钉①固定好。

The temporary stop switch has been in the state as shown in figure A at the time of delivery. Loosen setscrew ① and set the switch in the state as shown in figure B, and fix it with setscrew ① together with setscrew ② supplied with the machine.

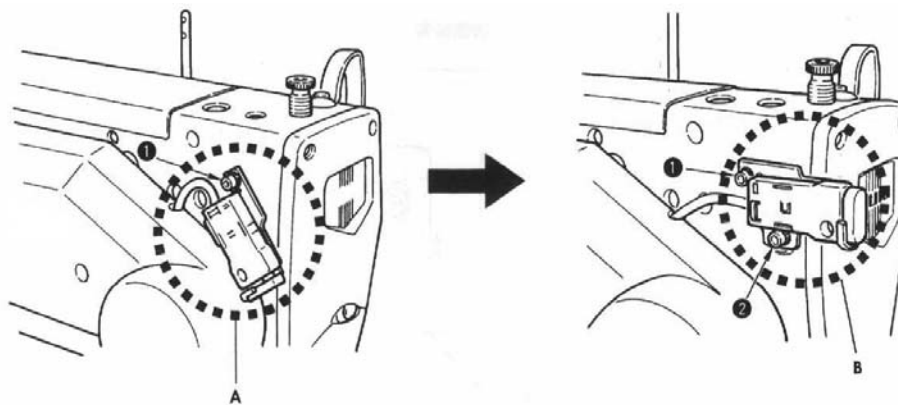

### (11) 过线柱/Thread guide rod

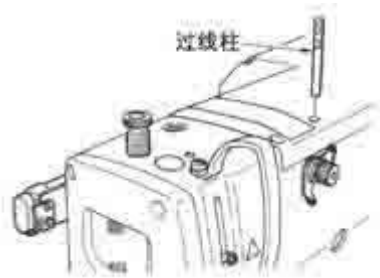

请把过线柱按 2 个横孔朝向正面的方向安装好。

Securely fit the thread guide rod so that two side holes in the thread guide rod face the thread guide.

### (12) 线架装置的安装/ Installing the thread stand

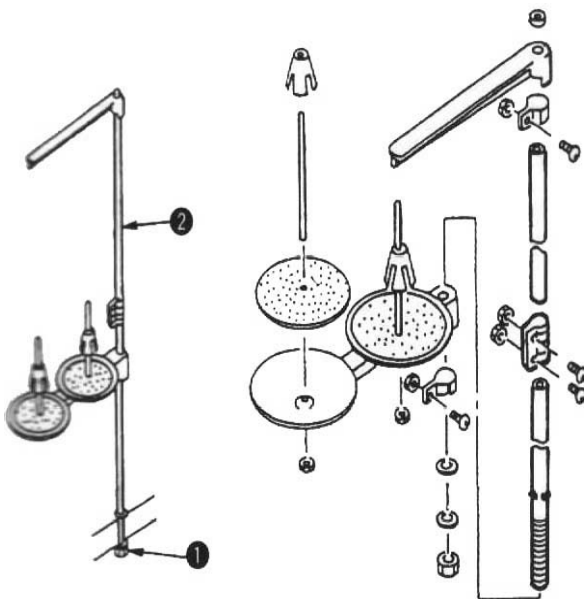

- 1) 安装线架装置，把它安装到台板右上的孔里。
- 2) 拧紧固定螺母①，不让线架装置松动。
- 3) 如果顶部可以配线时，请把电源线从线架杆②中穿过去。

- 1) Assemble the thread stand, and set it in the hole in the top right corner of the machine table.
- 2) Tighten locknut① to fix the thread stand.
- 3) When ceiling wiring is possible, pass the power cord through spool rest rod ②.

## IV、缝纫机开机前的准备/ PREPARATION BEFORE OPERATION

### (1) 加油/ Lubrication

★注意：为了防止突然启动造成人身事故，请关掉电源，确认马达停止转动后再进行。

**WARNING :** To protect against possible personal injury due to abrupt start of the machine, be sure to start the following work after tuning the power off and ascertaining that the motor is at rest.

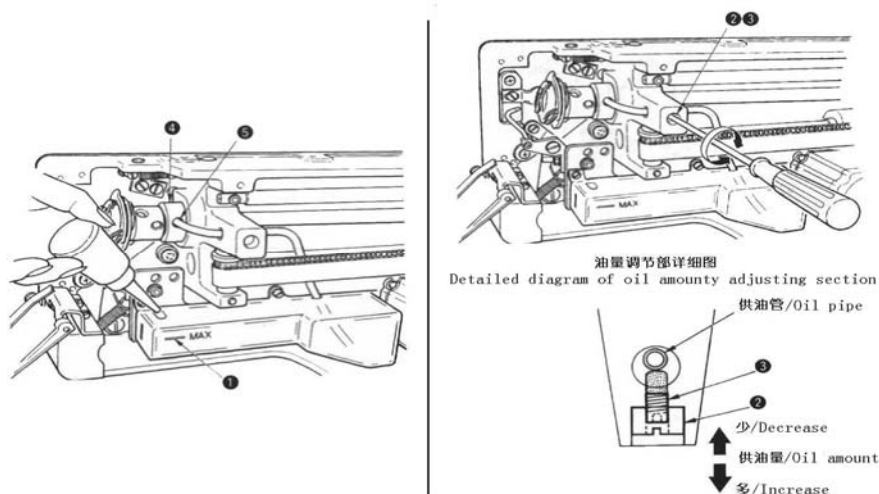

#### 1) 向油箱里加油

○把机油加满到 MAX 记号的位置①。

#### 2) 旋梭油量的调整

○拧松油量调节固定螺母②，然后用油量调节螺钉③进行调节。

○调节旋梭的油量时，拧进油量调节螺钉③则油量减少。

○油量调节后，请用固定螺母②进行固定。

○新装缝纫机或较长时间没有用过的缝纫机，使用之前请取下梭壳，在旋梭边槽加 2~3 滴机油。另外，向下轴前套④的加油孔⑤加几滴油，把油浸润到里面的毛毡里。

#### 1) Lubrication oil to oiling tank.

○ Fill the oiling tank with Oil up to the level indicated by “MAX .①” .

#### 2) Adjusting the lubrication for the sewing hook

○ Adjust the amount of oil supplied to the sewing hook by loosening lock nut ② and turning of amount adjusting screw ③.

○ Amount of supplied oil is reduced when turning the screw ③ clockwise

○ Fix the screw with lock nut ② after adjusting the lubrication for the sewing hook .

○ When you first operate your sewing machine after set-up or after an extended period of disuse ,remove the bobbin case and apply a few drops of oil to the hook race .In addition, apply a few drops oil from oiling hook⑥ in hook driving shaft front metal ④ to soak the inside felt in oil .

## (2) 机针的安装方法/Inserting the needle

★危险：为了防止突然启动造成人身事故，请关掉电源，确认马达停止转动再进行。

★WARNING : To protect against possible personal injury due to abrupt start of the machine, be sure to start the following work after tuning the power off and ascertaining that the motor is at rest.

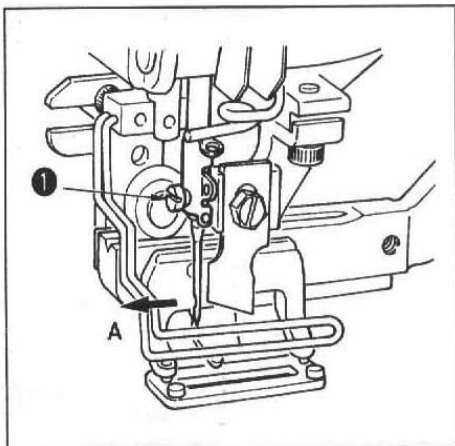

- 1) 从缝纫机的正面看，把机针凹部横向转到前侧 A。
- 2) 然后把机针插进针杆孔的最深处，拧紧机针固定螺钉①。
- 3) 机针使用 DPx5-(#11J~#14J)。

注意：安装机针时，请一定关掉电源

- 1) Hold needle with its recessed part facing toward the operator side A.
- 2) Insert the needle fully into the needle champing hole ,and tighten needle setscrew ①.
- 3) Use a DPx 5(#11J ~#14J).

▶ CAUTION : When attaching the needle, turn OFF the power to the motor.

### (3) 上线的穿线方法/Threading the needle-thread

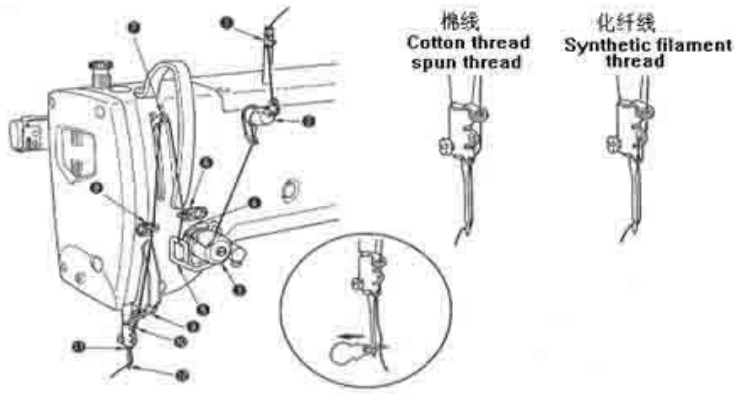

- 1) 上线如图①~⑫的顺序行穿线。
- 2) 把线穿针时，使用附件的穿线器时操作会更加方便。
- 3) 使用机线不同，导线器的穿线方法也不同。

- 1) Pass the needle thread in the order ① to ⑫ as shown in the figures.
- 2) The threading can be done easily by using the needle threader supplied with the machine.
- 3) Change the thread guide threading method according to the thread to be used.

### (4) 梭壳的穿线方法/Threading the bobbin case

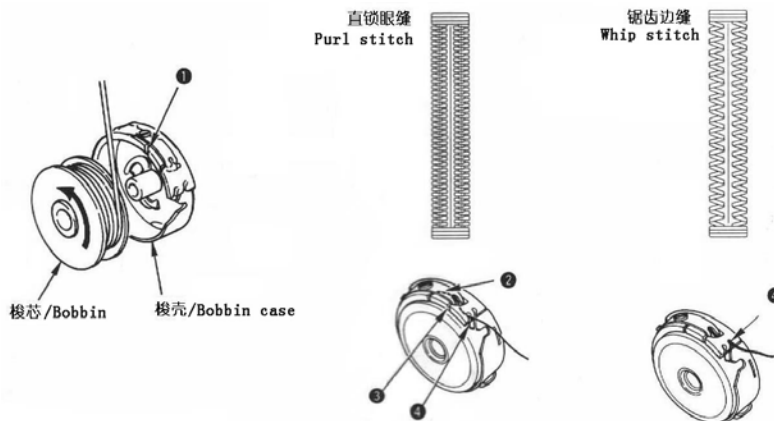

#### 梭芯转动方向和穿线方法

- 1) 头所示方向把梭芯插进去。
- 2) 请把缝线穿过穿线口①，然后再从张力弹簧②的下面穿过去，再次穿过穿线口，从④把线拉出来。
- 3) 请注意进行直锁眼缝和锯齿缝时，④的穿线方法不同。

#### Rotating direction of bobbin and threading

- 1) Fit the bobbin so that it rotates in the direction of the arrow.
- 2) Pass the thread through thread slit ①, then through under the tension spring ②, again through thread slit ③, and pull the thread from ④.
- 3) Threading at ④ for purl stitching is different from that for whip stitching. So, be careful.



## (5) 底线张力的调整/Adjusting the bobbin thread tension

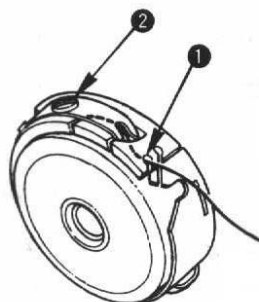

在梭壳穿线口①在上方的位置，把底线向上拉出之后，请按照下列的方法调整底线张力。

直锁眼缝	0.05~0.15N	手拿从梭壳出来的线头，轻轻地上下摆动时，梭壳就稍稍下降
锯齿边缝	0.15~0.3N	手拿从梭壳出来的线头，用稍稍强的力量摆动时，梭壳才下降

- 1) 把线张力螺钉②向右转动，底线张力变强，向左转动，底线张力变弱。
- 2) 使用化纤缝纫机线时，请把张力稍稍减弱，棉纱线时请稍稍加强。因为本机装有防止空转弹簧，所以装上旋梭之后的线张力请再调强 0.05N 左右。

►注意：调整了底线张力之后，请确认存储器开关的上线张力设定。

Adjust the bobbin thread tension as given below when the bobbin thread is pulled up at the position where thread slit ① of bobbin case comes up .

Purl stitch	0.05~0.15N	To such an extent that bobbin case quietly comes down when holding thread end coming from bobbin case and shaking it quietly up and down.
Whip stitch	0.15~0.3N	To such an extent that bobbin case barely comes down when holding thread end coming from bobbin case and shaking it somewhat strongly.

Turning tension adjust screw ②clockwise will increase bobbin thread tension and turning it counterclockwise will decrease the tension.

Adjust the bobbin thread tension to lower for synthetic filament thread, and to higher for spun thread .The thread tension is higher by approximately 0.05N when the bobbin case is set to the hook since idle-prevention spring is provided.

►CAUTION : When bobbin thread tension is adjusted, check the needle thread tension setting of the memory switch.

## (6) 梭壳的安装方法/Installation of bobbin case.

★注意：为了防止突然启动造成人身事故，请关掉电源，确认马达停止转动后再进行。

★ **WARNING:** To protect against possible personal injury due to abrupt start of the machine, be sure to start the following work after

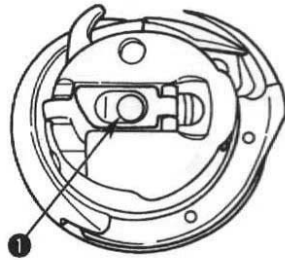

- 1) 扳起梭壳抓手。
- 2) 插入旋梭轴①，关闭抓手。梭壳被按到一定位置会听到喀喳的声音。

- 1) Lift up and hold bobbin case latch lever between two fingers.
- 2) Push the bobbin case into the hook so that it is supported by the hook shaft ① and then snap in the latch lever. Press the bobbin case until the predetermined position is reached, and it will click.

►注意：如果梭壳没有在规定的位罝，缝纫后梭心会飞出来，上线绕到旋梭轴上。

► **CAUTION:** If the bobbin case is out of the predetermined position, it can jump out from the hook to cause the needle thread to tangle on the hook shaft. Check to be sure that the bobbin case is properly installed in the correct position.

## (7) 切布刀的安装方法/Installing the knife

★注意：为了防止突然启动造成人身事故，请关掉电源，确认马达停止转动后再进行。

★ **WARNING** : To protect against possible personal injury due to abrupt start of the machine, be sure to start the following work after turning the power of and ascertaining that the motor is at rest.

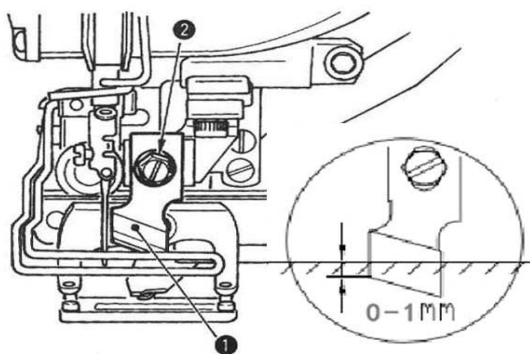

请按如下的步骤更换新的切布刀。  
 1) 卸下切布刀固定螺钉②之后，把切布刀①和垫片一起简单地卸下来。  
 2) 用手按下切布刀之后，把切布刀和针板上面的距离调整到 0~1mm,然后套上垫片，并拧紧固定。

When replacing the knife with a new one, perform as follows.

- 1) Knife ① can be easily removed together with the washer when removing knife retaining screw ②.
- 2) Adjust so that the knife, when lowered the knife bar by hand, is spaced to 2 mm away from the top surface of the throat plate as illustrated in the sketch. Then, be sure to place the washer and tighten the knife retaining screw.

inch→mm 换算表/Inch→mm CONVERSION TABLE mm CONVERSION TABLE

切布刀尺寸/inch Knife size /inch	mm 表示 Indication of mm	切布刀尺寸/inch Knife size /inch	mm 表示 Indication of mm
1/4	6.40	13/16	20.60
3/8	9.50	7/8	22.20
7/16	11.10	1	25.40
1/2	12.70	1 1/8	28.60
9/16	14.30	1 1/4	31.80
5/8	15.90	1 3/8	34.90
11/16	17.50	1 1/2	38.10
3/4	19.10		

## V. 维修

### 1. 机针和旋梭的同步时间调整

★ 危险：为了防止突然启动造成人身事故，请关掉电源，确认马达停止转动后再进行。

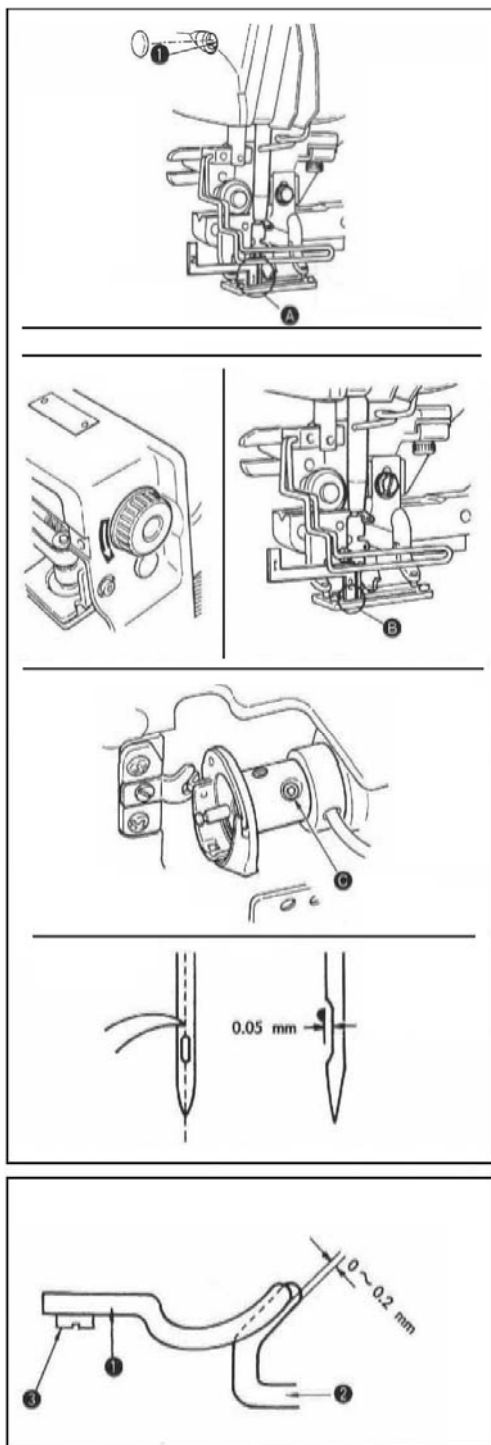

机针和旋梭的同步调节，请在机针落到针板孔的中央时调整。

#### (1) 针杆高度

- 1) 把针杆降到最下点；
- 2) 把高度尺[1]的部分如图所示插入针板和针杆下端之间，使针杆碰到高度尺；
- 3) 拧紧针杆套管固定螺钉①，决定针杆高度。

#### (2) 机针和旋梭的同步

- 1) 按逆时针的转动主向转手轮，让机针从最下点开始上升；
- 2) 把高度尺[2]的部分插入针板和针杆下端之间，让针杆顶到高度尺；
- 3) 拧松轴套固定螺钉，把旋梭尖调整到机针的中心；
- 4) 此时，机针与旋梭尖之间的间隙为约 0.05mm，距离过大会导致跳针，过小会磨损旋梭尖；

#### (3) 内旋梭的固定和调整

用固定螺钉④把内旋梭固定器①的前端和内旋梭②的端面的咬合调整为 0~0.2mm

## V. MAINTENANCE

### 1. Adjusting the needle-to-hook relation

★ **WARNING :** To protect against possible personal injury due to abrupt start of the machine, be sure to start the following work after turning the power off and ascertaining that the motor is at rest.

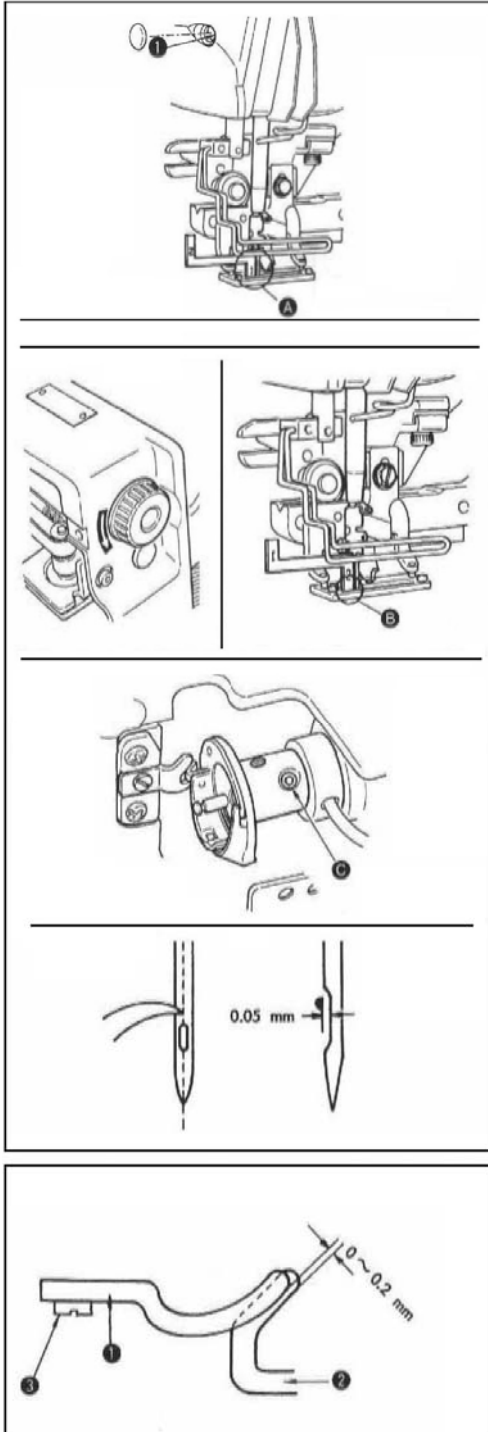

**Adjust the needle-to-hook relation when the needle enters the center of the needle hole in the throat plate**

#### (1) Needle bar height

Bring down the needle bar to the lowest point.  
Insert the part [1] of timing gauge into the gap between the bottom end of needle bar and throat plate, where the bottom end of the needle bar touches the top of the part [1] of the timing gauge.  
Loosen needle bar connection screw ❶, and adjust the height of the needle bar.

#### (2) Set the needle to hook relation in the following way:

Rotate the hand pulley in the correct direction until the needle starts to go up from its lowest point.

Inset the part [2] of the timing gauge into the gap between the bottom end of the needle bar and the throat plate, where the bottom end of the needle bar touches the top of the part [2] of the timing gauge.

Loosen setscrew of the hook sleeve, and align blade point of the sewing hook with the center of needle hole. Make adjustment so that a clearance of approx. 0.05mm is provided between the needle and the blade point of the hook.

#### (3) Adjusting the bobbin case positioning stopper

Adjust with setscrew ❸ so that the contact of the top end of bobbin case positioning stopper ❶ and the end of inner hook ❷ is 0 to 0.2mm.

## 2. 上线切线的调整/ adjusting the needle thread trimmer

★注意：为了防止突然启动造成人身事故，请关掉电源，确认马达停止转动后再进行。

★CAUTION : To protect against possible personal injury due to abrupt start of the machine, be sure to start the following work after turning the power off and ascertaining that the motor is at rest.

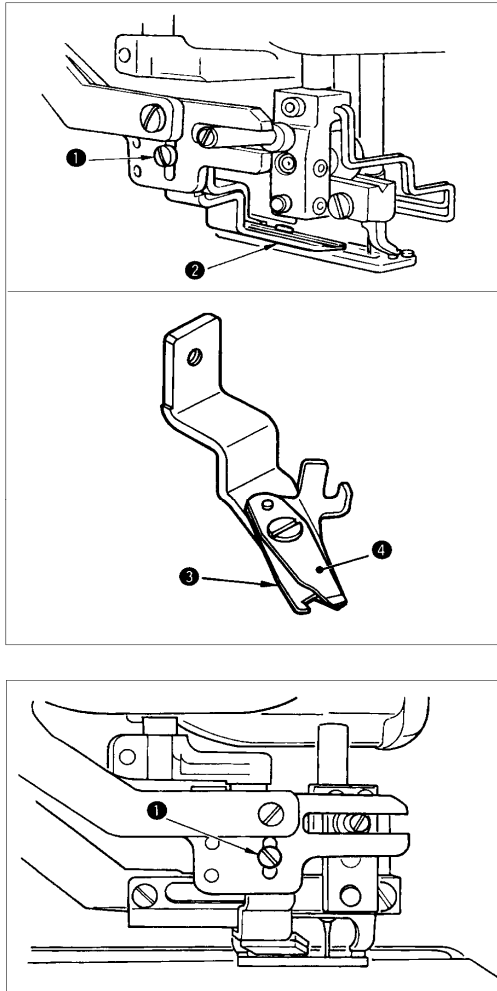

### (1) 上线切刀的切线力的调整

上线切刀切线力不稳定时，始缝时上线容易跳线。

- 1) 切线力弱时拧松螺丝①，卸下上线切刀②。
- 2) 把压线弹簧前端轻轻弄弯，把切线压板③和上切刀④的接触间隙调整为没有。

### (1) Adjusting the thread grasping force of the needle thread trimmer

If the needle thread trimmer fails to provide consistent thread grasping force, the needle thread can slip off at the beginning of sewing.

- 1) If the thread grasping force of the needle thread trimmer has reduce, loosen setscrew ① and detach needle thread trimmer ②.
- 2) Slightly bend the top end of thread presser spring ③ so that it comes in contact with thread trimming blade of upper knife ④ over the length with no clearance and so that the needle thread trimmer securely holds the thread regardless of the position of the thread trimming blade at which the thread is trimmed.

### (2) 上切刀的安装高度

请拧紧上切刀安装螺钉①调整上切刀的安装高度。在上切刀和压脚不接触的情况下请尽量调低压脚，这样上线切刀残线长度较短。

但是缝纫多层布时，压脚会倾斜。请把位置稍稍提高，确保切刀与压脚相碰。

### (2) Adjusting the height of the needle thread trimmer

To adjust the height of the needle thread trimmer, loosen setscrew ①. Set the height of trimmer as low as possible, provided that it does not touch work clamp check, in order to minimize the length of remaining thread on the needle after trimming.

Note that the work clamp check tilts when sewing a multi-layered portion of the material, attach the needle thread trimmer to slightly raise the installing position of the trimmer.

### 3. 压脚压力的调整/adjusting the presser bar pressure

★注意：为了防止突然启动造成人身事故，请关掉电源，确认马达确实停止转动后再进行。

★CAUTION : To protect against possible personal injury due to abrupt start of the machine, be sure to start the following work after turning the power off and ascertaining that the motor is at rest.

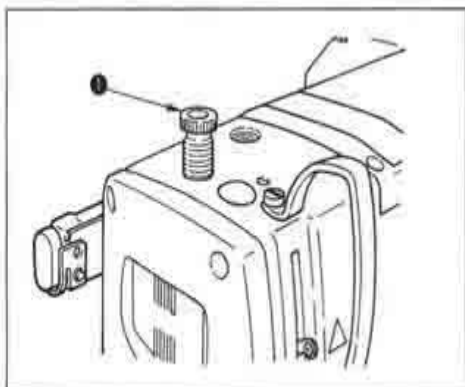

压脚的压力用压脚调节螺钉①调节。拧紧调节螺钉①后，压脚压力变大，布不容易起皱。

To adjust the pressure applied by the presser bar to fabric, turn presser spring regulator ①. When the pressure is not enough to prevent fabric from puckering, turn regulator ①clockwise.

#### 4. 旋梭定位钩座位置的调整/Adjusting of the bobbin presser unit

★ **注意：** 为了防止突然启动造成人身事故，请关掉电源，确认马达确实停止转动后再进行。

★ **CAUTION** : To protect against possible personal injury due to abrupt start of the machine, be sure to start the following work after turning the power off and ascertaining that the motor is at rest.

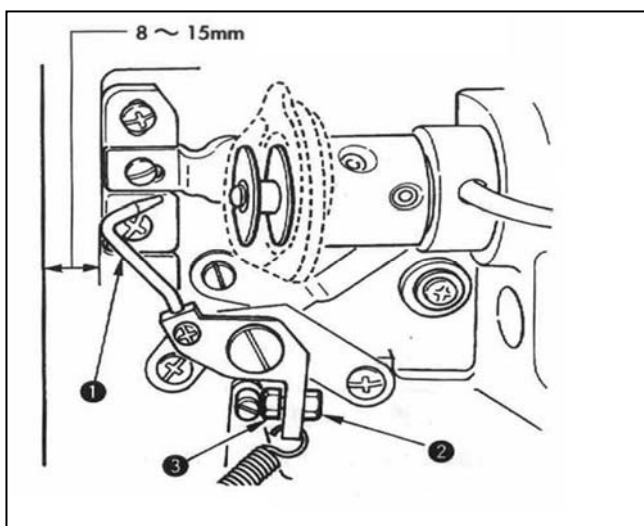

缝纫机停止时，拧松挑线连接块复位螺钉螺母②把底板前端和旋梭定位钩座①的距离调整为 8~15mm,然后用挑线连接块复位螺钉③调整位置，再拧紧螺母②。

Loosen nut ② and adjust the position with stopper spring ③ so that the distance from the front end of machine bed to bobbin presser ① is 8 to 15mm when the sewing machine stops. Then tighten nut ②.



## 5. 线张力/Thread tension

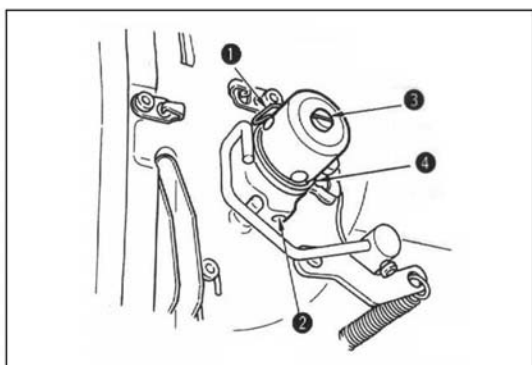

### (1) 挑线弹簧（直锁眼缝）

1)挑线弹簧①的挑线量为 8~10mm, 开始强度 0.06~0.1N 左右较为适当。

2)改变挑线弹簧的动作量时,请拧松螺钉②,把螺丝刀插到线张力杆③的缺口部转动调节。

3)改变挑线弹簧的强度时,请在螺钉②拧紧的状态下,把螺丝刀插到线张力杆③的缺口部转动调节。向右转动之后,挑线弹簧的强度变强,向左转动之后,强度变弱。

### (1) Thread take-up spring (purl stitch)

1) The thread take-up amount of thread take-up spring ① is 8 to 10mm, and the appropriate pressure at the start is approximately 0.06 to 0.1N.

2) To change the stroke of the thread take-up spring, loosen screw ②, insert a thin screwdriver into the slot of thread tension post ③, and turn it.

3) To change the pressure of the thread take-up spring, insert a thin screwdriver into the slot of thread tension post ③ while screw ② is tightened, and turn it. Turning it clockwise will increase the pressure of the thread take-up spring.

Turning it counterclockwise will decrease the pressure.

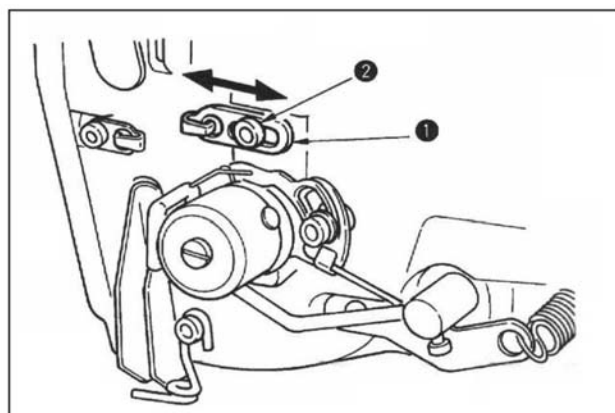

### (2) 挑线杆挑线量的调整

挑线杆挑线量,根据布料的厚度进行调节。

a. 缝制厚料时,拧松右线勾①的固定螺钉②,向左移动右线勾。

b. 缝制薄料时,把右线勾①向右移动。挑线杆的挑线量变少。

### (2) Adjusting the thread take-up amount of the thread take-up lever

The thread take-up amount of the thread take-up lever should be adjusted in accordance with the thickness of the sewing products so as to obtain well-tightened stitches.

a. For heavy-weight materials, loosen setscrew ② in thread guide ①, and move the thread guide to the left the thread take-up amount of the thread take-up lever will be increased.

b. For light-weight materials, move thread guide ① to the right. The thread take-up amount of the thread take-up lever will be reduced.

## 6. 滤清器的清扫/Cleaning the filter

★注意： 为了防止突然启动造成人身事故，请关掉电源，确认马达停止转动后再进行。

★ **WARNING** : To protect against possible personal injury due to abrupt start of the machine, be sure to start the following work after turning the power off and ascertaining that the motor is at rest.

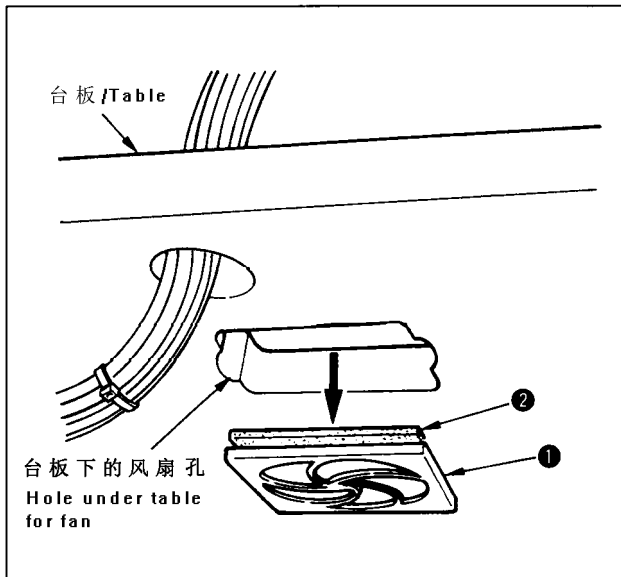

请每周清洗台板下面的风扇过滤器①

- 1)沿箭头方向拉过滤网②，把它卸下来。
- 2)用水冲洗清扫滤清器①。
- 3)把滤清器①、过滤网②安装到原来的位置。

Clean filter ① of the fan located on the bottom surface of the machine table (bed base) once every week.

- 1) Pull the screen kit ② in the direction of the arrow to remove it.
- 2) Wash the filter ① under running water.
- 3) Reinstall the filter ① and the screen kit ②.

## 故障现象与原因、处理对策/TROUBLES AND CORRECTIVE MEASURES

现象	原因	处理对策	页
1. 上线断线	1. 平行部张力过强;	○减弱平行部张力;	—
	2. 挑线弹簧的强度过强, 移动量过大;	○减弱挑线弹簧的弹力, 或缩小移动量;	24
	3. 旋梭尖部分有毛刺, 有伤痕;	○锉平旋梭尖的毛刺, 或更换旋梭;	—
	4. 旋梭的同步时间不对;	○用高度尺调整旋梭的同步时间;	19
	5. 线道上有伤痕;	○用布或锉刀去除伤痕和毛刺;	—
	6. 机针安装不良;	○调整机针的朝向和高度;	14
	7. 机针过细;	○更换成粗机针;	14
	8. 机针的前端有伤痕;	○更换机针;	14
2. 上线脱线	1. 上线切刀张开过早;	○推迟上线切刀张开时间;	—
	2. 始缝部线勾不到一起 (始缝的张力过强);	○减弱始缝张力;	—
	3. 上线穿线方法不对;	○重新正确地穿线;	15
	4. 始缝的速度过快;	○设定软起动;	—
3. 平行部缝迹不均匀	1. 平行部线张力过弱;	○增强平行部线张力;	—
	2. 底线张力过强;	○减弱底线张力;	—
	3. 钮扣整体张力过弱;	○增强上夹线器张力;	—
4. 始缝缝迹不均匀	1. 平行部张力过弱;	○加强平行部张力;	—
	2. 上线切刀位置过高;	○不碰到压脚的前提下尽量下降压脚;	21
	3. 挑线弹簧的移动量过大;	○减小挑线弹簧的移动量;;	24
5. 加固缝部上线从布的下面露出, 成圈状	1. 加固缝线张力过弱;	○增强加固缝线张力;	—
	2. 底线张力过强;	○减弱底线张力;	—
	3. 缝放射状的图案时放射针数过多;	○减少放射针数;	—
	4. 结束缝的张力过弱;	○增强结束缝线张力;	—
6. 缝迹鼓起	1. 底线张力过弱;	○增强底线张力;	16
	2. 底线从梭壳中脱出来;	○重新正确地穿梭壳线;	15
		○底线卷绕量绕得不要过多;	—
7. 锁眼绽出	1. 钮扣孔比压脚小;	○把压脚更换成更小的;	—
	2. 缝制薄料时皱缩;	○推迟机针和旋梭的同步时间 (把针杆下降 0.5mm 左右);	19
	3. 机针安装不好;	○重新调整机针的朝向、高度等;	14
	4. 机针弯曲;	○更换机针;	14
	5. 旋梭尖部有毛刺或伤痕;	○用锉刀锉平梭尖或更换旋梭;	—
8. 线绽开	1. 固定缝针数少;	○增加缝制结束时加固缝的针数;	—
	2. 固定缝宽度过宽;	○减小缝制结束时的加固缝宽度;	—
9. 缝制结束上线留线过长	1. 固定缝宽度过窄;	○增加缝制结束时的加固缝针数;	—
	2. 固定缝张力过弱;	○减小缝制结束时的加固缝宽度;	—
10. 始缝时上线断线, 或者背面线迹不好;	1. 始缝张力过弱;	○增强始缝张力;	—

<b>Trouble</b>	<b>Causes</b>	<b>Corrective measures</b>	<b>Page</b>
1. Needle thread breakage	<ol style="list-style-type: none"> <li>1. Thread tension at parallel section is too high.</li> <li>2. Pressure or stroke of thread take-up spring is too large.</li> <li>3. There is a burr or scratch on the blade point of hook.</li> <li>4. Hook timing is not proper.</li> <li>5. There is a scratch on the thread path.</li> <li>6. Attaching needle is wrong.</li> <li>7. Needle is too thin.</li> <li>8. Needle tip is damaged.</li> </ol>	<ul style="list-style-type: none"> <li>○ decrease the thread tension at parallel section.</li> <li>○ decrease the tension of thread take-up spring or decrease its stroke.</li> <li>○ Buff the blade point of hook. Or, replace the hook.</li> <li>○ Adjust again the hook timing with timing gauge.</li> <li>○ Polish the thread path with sand paper and buff it.</li> <li>○ Adjust again the direction, height, etc.</li> <li>○ Replace the needle with a thicker one.</li> <li>○ 更 Replace the needle.</li> </ul>	— 24 — 19 — 14 14 14
2. Needle thread slips off.	<ol style="list-style-type: none"> <li>1. Needle thread trimmer opens too early.</li> <li>2. Whip stitching is not formed at the start of sewing.(tension ).</li> <li>3. Threading needle thread is wrong.</li> <li>4. Speed at the start of sewing is too fast.</li> </ol>	<ul style="list-style-type: none"> <li>○ Delay the opening timing of the needle thread trimmer.</li> <li>○ Decrease tension at the start of sewing.</li> <li>○ Thread properly again.</li> <li>○ Set the soft-start function.</li> </ul>	— — 15 —
3. Wobbling at parallel section	<ol style="list-style-type: none"> <li>1. Thread tension at parallel section is too low.</li> <li>2. Bobbin thread tension is too high.</li> <li>3. Pre-tension is too low.</li> </ol>	<ul style="list-style-type: none"> <li>○ Increase the thread tension at parallel section.</li> <li>○ Decrease bobbin thread tension.</li> <li>○ increase pre-tension.</li> </ul>	— — —
4. Wobbling at the start of sewing	<ol style="list-style-type: none"> <li>1. Thread tension at parallel section is too low.</li> <li>2. Position of needle thread trimmer is too high.</li> <li>3. Stroke of thread take-up spring is too large.</li> </ol>	<ul style="list-style-type: none"> <li>○ Increase the thread tension at parallel section.</li> <li>○ Lower the needle thread trimmer to such an extent that it does not come in contact with the presser.</li> <li>○ Decrease the stroke of thread take-up spring.</li> </ul>	— 21 24
5. Needle thread appears on the wrong side of material at bar-tacking section in dumpling condition.	<ol style="list-style-type: none"> <li>1. Bar-tacking thread tension is too low.</li> <li>2. Bobbin thread tension is too high.</li> <li>3. Number of stitches of radial shape is too many.</li> <li>4. Tension at the end of sewing is too many.</li> </ol>	<ul style="list-style-type: none"> <li>○ Increase the bar-tacking thread tension.</li> <li>○ Decrease the number of stitches</li> <li>○ Decrease the number of stitches.</li> <li>○ Increase tension at the end of sewing.</li> </ul>	— — — —
6. Stitches float.	<ol style="list-style-type: none"> <li>1. Bobbin thread tension is too low.</li> <li>2. Bobbin thread comes off bobbin case.</li> </ol>	<ul style="list-style-type: none"> <li>○ Increase the bobbin thread tension.</li> <li>○ perform proper threading the bobbin case.</li> <li>○ take care that the winding amount of bobbin thread is not excessive.</li> </ul>	16 15 —
7. Stitch skipping	<ol style="list-style-type: none"> <li>1. Button hole is small in terms of the</li> </ol>	<ul style="list-style-type: none"> <li>○ Replace the presser with a smaller</li> </ul>	—

	<p>size of presser.</p> <p>2. Material flops because of light-weight.</p> <p>3. Attaching needle is wrong.</p> <p>4. Needle id bent.</p> <p>5. There is a burr or scratch on the blade point of hook.</p>	<p>one.</p> <p>○ Delay the hook-to-needle timing. (Lower the needle bar by 0.5mm);</p> <p>○ Adjust again the direction, height, etc.</p> <p>○ Replace the needle.</p> <p>○ Buff the blade top of hook. Or, replace the hook.</p>	<p>19</p> <p>14</p> <p>14</p> <p>—</p>
8. Thread frays.	<p>1. Number of stitches of the stitching is too small.</p> <p>2. Width of tie stitching is too wide.</p>	<p>○ Increase the number of stitches of tie stitching at the end of sewing.</p> <p>○ Narrow the width of tie stitching at the end of sewing.</p>	<p>—</p> <p>—</p>
9. Length of needle thread remaining at the end of sewing is too long.	<p>1. Width of tie stitching is too narrow.</p> <p>2. Tension of tie stitching is too low.</p>	<p>○ Widen the width of tie stitching at the end of sewing.</p> <p>○ Increase tension at the end of sewing.</p>	<p>—</p> <p>—</p>
10. Needle thread breaks at the start of sewing, or the wrong side of seam is dirty.	<p>1. Tension at the start of sewing is too low.</p>	<p>○ Increase tension at the start of sewing.</p>	<p>—</p>

# CONTENTS

## 目录

1. FRAME & MISCELLANEOUS COVER COMPONENTS I .....	01
机壳部件 I	
2. FRAME & MISCELLANEOUS COVER COMPONENTS II .....	04
机壳部件 II	
3. MAIN SHAFT COMPONENTS.....	07
上轴部件	
4. HOOK DRIVING SHAFT COMPONENTS.....	10
下轴部件	
5. PRESSER& FEED COMPONENTS.....	12
送料、抬压脚部件	
6. NEEDLE BAR ROCKING COMPONENTS.....	15
摆针部件	
7. NEEDLE THREAD TRIMMER COMPONENTS.....	17
上切线部件	
8. BOBBIN THREAD TRIMMER COMPONENTS.....	20
下切线部件	
9. CLOTH CUTTING KNIFE COMPONENTS.....	23
切布刀部件	
10. ACCESSORIE PART COMPONENTS.....	25
附件...	
11. THREAD STAND COMPONENTS.....	27
过线架部件	
12. CONTROL BOX COMPONENTS.....	28
电控部件	

# 1. FRAME & MISCELLANEOUS COVER COMPONENTS I

机壳部件 I

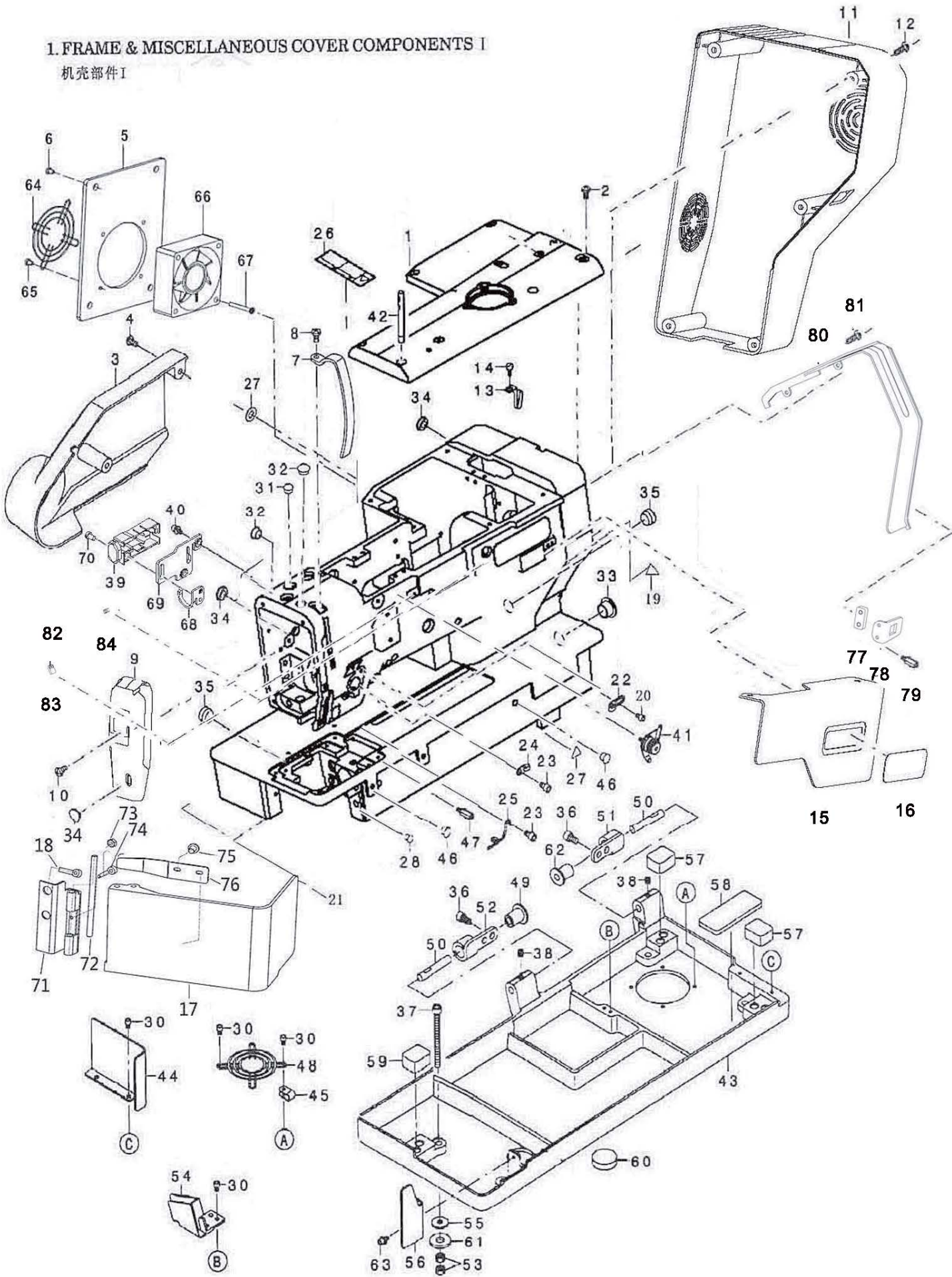

1. 头部、外装关系I				
FRAME&MISCELLANEOUS COVER COMPONENTS I				
序号 NO.	件号 Part No.	描述	Description	数量
1	20025842	上盖☆	UPPER COVER	1
2	10003883	上盖螺钉	SCREW	6
3	20025843	左盖☆	LEFT COVER	1
4	10003883	左盖螺钉	SCREW	2
5	20003383	左盖板	LEFT COVER B	1
6	10003883	左盖板螺钉	SCREW	4
7	20025840	挑线杆防护罩	THREAD TAKE UP LEVER COVER	1
8	10003883	挑线杆防护螺钉	SCREW	1
9	20025839	面板☆	FRONT COVER	1
10	10003883	面板螺钉	SCREW	3
11	20025844	后罩☆	MOTER COVER	1
12	10003827	后罩螺钉	SCREW M5 L=16	4
13	10003446	总线夹	CABLE CLAMP	1
14	10003399	电线夹螺钉	SCREW M4 L=10	1
15	10065185	发光LOGO电路板组件	LUMINOUS LOGO CIRCUIT BOARD ASSEMBLY	1
16		发光LOGO	LUMINOUS LOGO	1
17	20003432	底板前盖板	HOOK OIL SHIELD COVER COMPL.	1
18	10003881	底板前盖板螺钉	HEXAGON SOCKET HEAD SCREW M5*6	2
19	10005987	接地标志	GROUNDING SYMBOL	1
20	10003399	右线钩螺钉	SCREW M4 L=6	1
21	10003359	过线槽	THREAD GUIDE TROUGH	1
22	10003419	右线钩	TAKE-UP THREAD GUIDE A	1
23	10003396	螺钉	SCREW M5 L=8	2
24	10003423	左线钩	TAKE-UP THREAD GUIDE B	1
25	10003873	下过线钩	NEEDLE BAR THREAD GUIDE	1
26	10008936	安全指示牌	SAFETY LABEL 12	1
27	10003353	左盖垫	CLOTH PLATE WASHER	1
28	10003426	底板前盖板垫	RUBBER PLUG	1
29	10000091	上盖前油塞	PLUG D=7.5 L=3.5	2
30	10003399	螺钉	SCREW M4 L=6	6
31	10011136	背部前端油塞	RUBBER PLUG	1
32	10011099	油塞	RUBBER PLUG	2
33	10003880	底板后端油塞	RUBBER PLUG	1
34	10011099	油塞	RUBBER PLUG D=12.5 L=4	3
35	10003871	油塞	RUBBER PLUG	2
36	10003402	机头铰链螺钉	SCREW M6 L=10	4
37	10003832	底座锁紧螺钉	HEXAGON BOLT	4
38	10011232	连接销紧定螺钉	SCREW M6 L=6	2
39	10003870	点动开关组件	SWITCH ASM.	1
40	10003875	点动开关组件螺钉	SCREW	2
41	10000131	上夹线器组件☆	PRE TENSION CONTROLLER ASM.	1
42	10000167	两眼过线柱	THREAD GUIDE BAR	1
43	10003878	底座	BED BASE	1
44	20003381	底座后盖板	BED REAR COVER	1
45	10003358	电线夹	CABLE CLAMP	1
46	10000405	油塞	RUBBER PLUG	2



47	10003413	眼睛防护罩安装柱	VCS STUD A	1
48	10003397	风扇安装架组件	FAN SHELTER ASM	1
49	10003347	机头铰链套	HINGE BUSH	1
50	10003884	连接销	HINGE PIN	2
51	10003443	机头后铰链	HINGE PLATE A	1
52	10003831	机头前铰链	HINGE PLATE B	1
53	10005504	调节螺母	NUT M6	8
54	10003888	安全开关组件	SAFETY SWITCH COVER	1
55	10003395	底座锁紧螺钉垫片	WASHER 6.1X18.5X2	4
56	10003453	挡油板	OIL SHIELD	1
57	10003415	底座垫II	RUBBER A	2
58	10003829	底座长垫	CUSHION	1
59	10003415	底座垫I	RUBBER	1
60	10003451	底座圆垫	Z STOPPER RUBBER	1
61	10003357	底座橡胶垫片	RUBBER CUSHION(B)	4
62	10003350	机头铰链橡胶套	RUBBER HINGE	1
63	10003875	挡油板螺钉	SCREW	1
64	10025134	金属防护罩	SHELTER CLAD	1
65	10003875	螺钉	SCREW	2
66	10025133	风扇组件	FAN ASM	1
67	10003444	风扇螺钉组件	FAN SCREW ASM	2
68	10053703	点动开关扣板	SWITCH GUARD	1
69	10003454	点动开关内盖板	SWITCH BASE	1
70	10013852	螺钉	SCREW	1
71	10003418	前盖板安装板	FRONT COVER MOUNTING PLATE	1
72	10003355	底板前盖板销	FRONT COVER PLATE PIN OF BOTTOM F	1
73	10003887	螺母	NUT M3	1
74	10003874	M3*14螺钉	SCREW M3 L=14	1
75	10003398	螺钉	SCREW	1
76	10003828	底板前盖板弹簧板	BOTTOM PLATE FRONT COVER SPRING F	1
77	10068355	电源安装板垫块	POWER SUPPLY MOUNTING PLATE PAD	1
78	10057431	电源开关安装座	POWER SWITCH MOUNTING SEAT	1
79	10068969	电源安装板螺钉	POWER SUPPLY MOUNTING PLATE SCREW	2
80	10067093	后装饰板	REAR TRIM PANEL	1
81	10003399	后装饰板螺钉	REAR TRIM PANEL SCREWS	3
82	10042402	卡紧扣	CARD BUCKLE	2
83	10053628	卡紧扣螺钉	CARD BUCKLE SCREWS	4
84		电路板插头	CIRCUIT BOARD PLUG	1

## 2. FRAME & MISCELLANEOUS COVER COMPONENTS II

机壳部件II

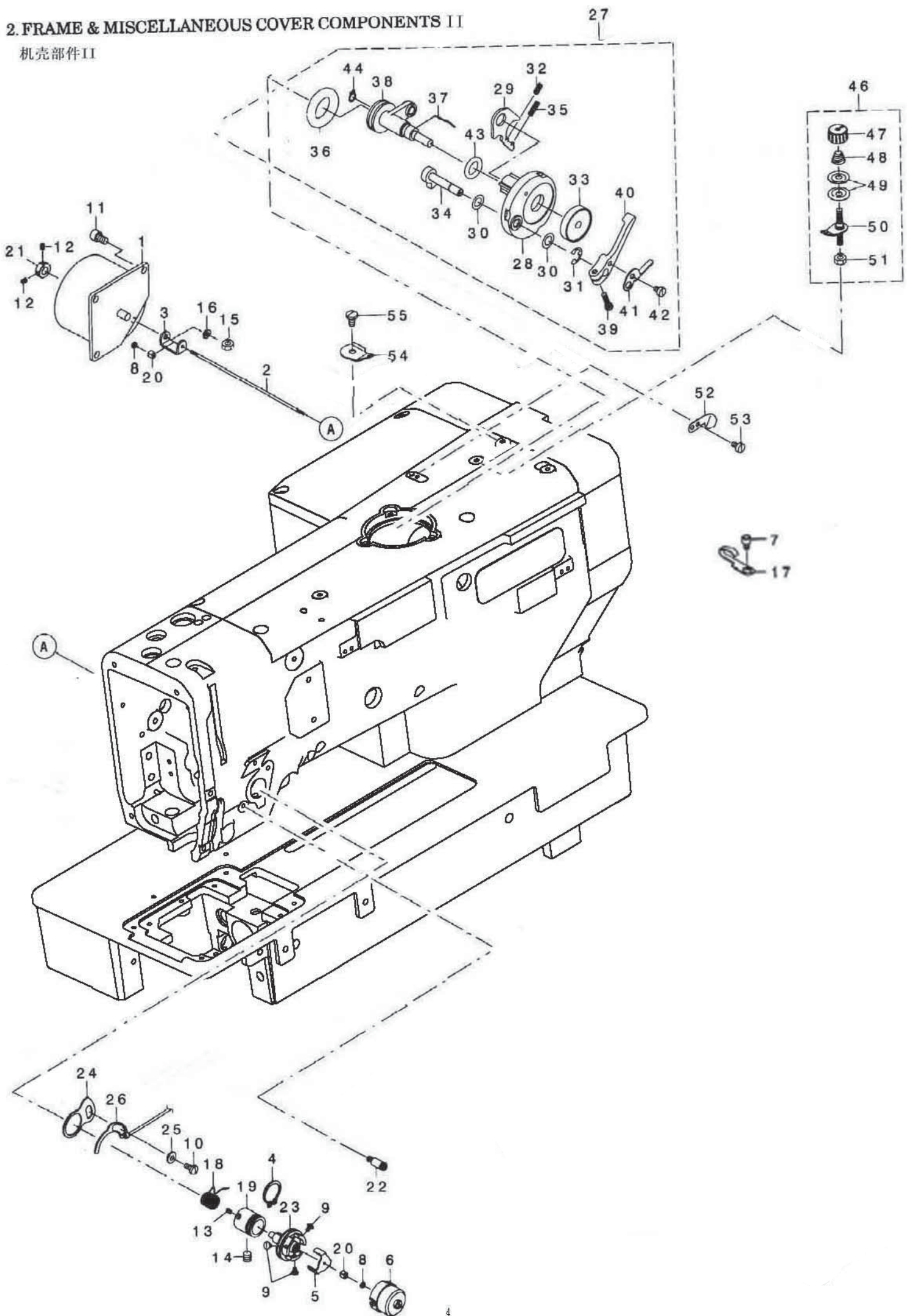

2. 机壳部件 II				
FRAME&MISCELLANEOUS COVER COMPONENTS II				
序号 NO.	件号 Part No.	描述	Description	数量
1	10000650	夹线电磁铁	ASSY_AT_SOLENOID	1
2	10000742	连接杆	AT_SHAFT	1
3	10000651	夹线电磁铁连接架	AT_SHAFT HOLDER	1
4	10050674	Φ17挡圈	RETAINING RING	1
5	10000755	夹线三分盘	DISK_STOPPER	1
6	10000756	夹线器外盖	DISK_STOPPER HOLDER_CAP	1
7	10003399	电线夹螺钉	SCREW M4 L=6	4
8	10000754	连接杆螺母锁紧螺母	NUT	2
9	10000743	外盖螺钉	SCREW	3
10	10000731	绝缘片螺钉	SCREW M4 L=8	1
11	10005490	夹线电磁铁螺钉	SCREW M L=10	3
12	10013019	挡圈螺钉	SCREW	2
13	10000746	夹线器座螺钉	SCREW M3 L=4	1
14	10011232	夹线器紧固螺钉	SCREW M6 L=6	1
15	10009471	连接铁芯螺母	NUT	1
16	10005415	连接铁芯螺钉垫圈	SPRING WASHER	1
17	10001122	油管夹	LUBRICATING OIL WICK STOPPER	4
18	10000069	挑线簧	TAKE-UP SPRING	1
19	10000749	夹线器座	THREAD_TENSION_POST_BASE	1
20	10000753	连接杆螺母	THREAD_TENSION_SHAFT_COLLAR	2
21	10000732	夹线电磁铁挡圈	THRUST COLLAR	1
22	10007123	缓冲垫架螺钉	UTT_SUSPENSION_SCREW_9	1
23	10000766	三分盘组件	ASSY_THREAD_TENSION_POST	1
24	10000741	传感片内绝缘片	GUIDE PLATE	1
25	10000752	传感片外绝缘片	BUSHING	1
26	10000758	断线检测传感片	THREAD BREAK DETECTOR A	1
27	10056117	绕线器组件	ASSY_BOBBIN_THREAD_WINDER	1
28	10011096	梭芯卷线体组件	BOBBIN FITTING BASIS COMPL.	1
29	10004497	控制板	ADJUSTING PLATE	1
30	10004486	薄垫片	VERTICAL ROLLER WASHER	2
31	10013038	绕线器凸轮轴挡圈	E-RING	1
32	10004494	弹簧	PRESSER FOOT SPRING	1
33	10000822	卷线轴垫	BOBBIN CUSHION	1
34	10006151	定位块	BOBBIN CAM SHAFT COMPLE.	1
35	10004501	弹簧	SPRING	1
36	10008773	橡胶轮	BTW RUBBER RING	1
37	10009937	锁心弹簧	LATCH SPRING	1
38	10000823	摆动板组件	ASSY_BTW_SHAFT	1
39	10000735	卷线手柄螺钉	SCREW 9/64 -40 L=13.5	1
40	10000736	卷线手柄	BOBBIN LEVER	1
41	10000737	绕线调节板	BOBBIN ADJUSTING PLATE	1
42	10000759	线量调节板螺钉	SCREW 9/64 -40 L=5.0	1
43	10004485	绕线轴O型圈	RUBBER RING	1
44	10006142	绕线器摆动板轴挡圈	RETAINING RING	1
45	10011101	绕线器螺钉	SCREW 11/64X40 L=11	3
46	10003088	绕线夹线器组件☆	BOBBIN THREAD TENSION ASM.	1

47	10004503	塑料夹线螺母	THREAD TENSION NUT	1
48	10004391	夹线簧	THREAD TENSION SPRING	1
49	10004393	夹线板	BOBBIN WINDER TENSION DISC	2
50	10003089	中过线板	BOBBIN THREAD TENSION ROD ASM.	1
51	10004507	夹线器螺母	NUT 11/64-40	1
52	10011149	绕线切刀	THREAD CUTTER	1
53	10000164	绕线切刀螺钉	SCREW 1/8-44 L=2.9	2
54	10000733	绕线过线板	THREAD GUIDE	1
55	10010668	绕线过线板螺钉	SCREW 11/64-40 L=7.8	1

### 3. MAIN SHAFT COMPONENTS

上轴部件

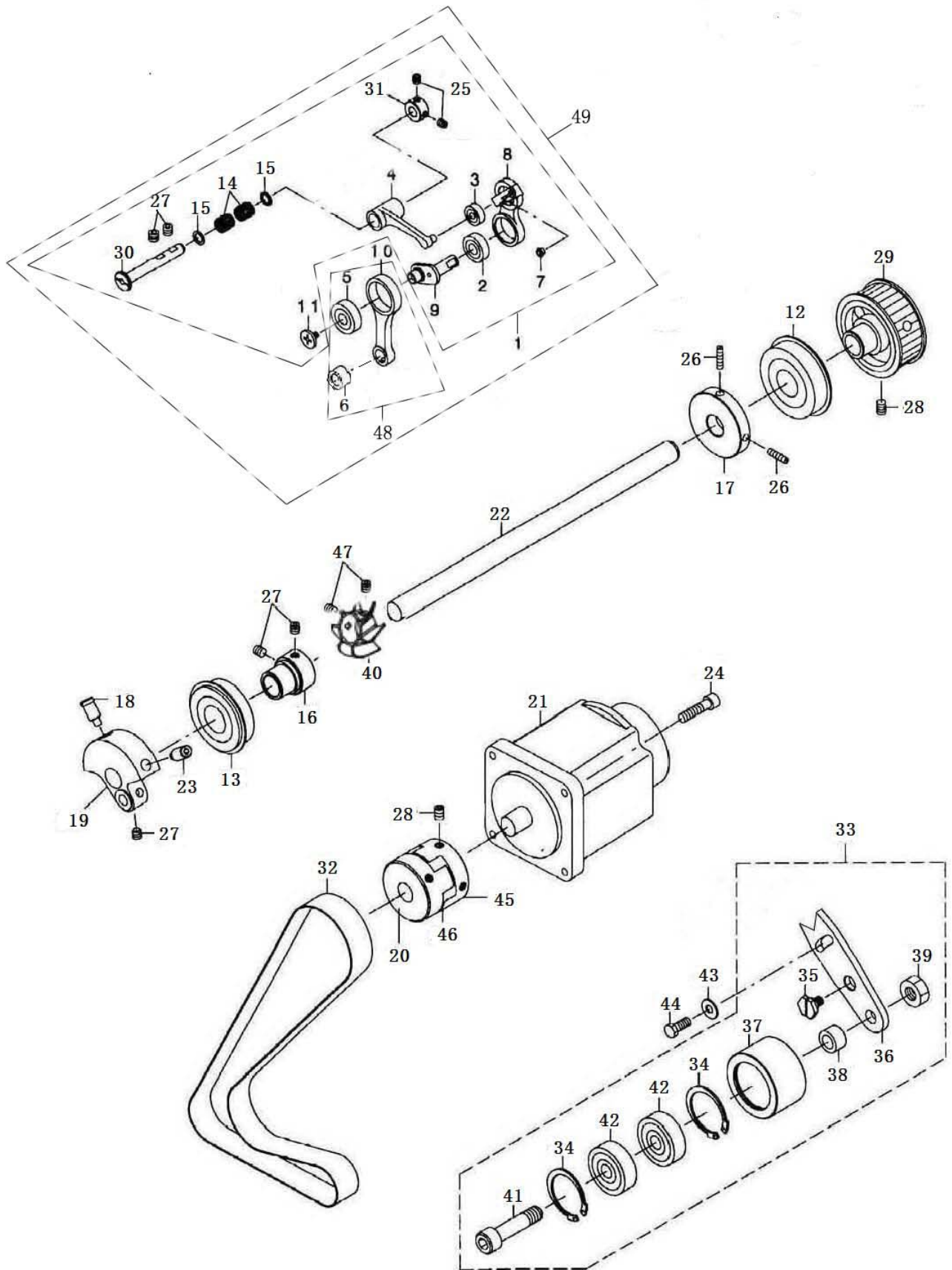

3. 上轴部件				
MAIN SHAFT&THREAD COMPONENTS				
序号 NO.	件号 Part No.	描述	Description	数量
1	10053752	挑线杆组件	THREAD TAKE UP ASM.	1
2	10009777	挑线杆大轴承	BEARING	1
3	10003552	挑线杆小轴承	BEARING	1
4	10000844	挑线连杆	THREAD TAKE UP CRANK	1
5	10014511	挑线连杆轴承	BUSHING	1
6	10052926	针杆连杆套	BUSH	1
7	10004161	挑线杆过线套	THREAD PASS BUSH	1
8	10000856	挑线杆	LINK TAKE UP	1
9	10000846	挑线曲柄	NEEDLE BAR CRANK	1
10	10000857	针杆连杆	NEEDLE BAR CRANK ROD	1
11	10010537	挑线曲柄左旋螺钉	LEFT SCREW	1
12	10025862	上轴后轴承	BEARING	1
13	10025881	上轴前轴承	BEARING	1
14	10005747	挑线杆铰链轴滚针轴承	BEARING	2
15	10005786	挑线杆铰链轴滚针轴承挡圈	BEARING SUPPORT	2
16	10000839	上轴前轴套	BEARING HOLDER	1
17	10013112	绕线驱动轮	BOBBIN WINDER DRIVING WHEEL	1
18	10000862	针杆曲柄定位螺钉	COUNTER_WEIGHT SCREW	1
19	10000861	针杆曲柄	COUNTER_WEIGHT	1
20	10000868	连接前块	COUPLING	1
21	10053759	上轴伺服电机	AC SERVO MOTOR	1
22	10000841	上轴	MAIN SHAFT	1
23	10000831	针杆曲柄紧定螺钉	SCREW M8 L=16	1
24	10000860	上轴伺服电机螺钉	SCREW M5 L=20	4
25	10012162	挑线曲柄轴挡圈螺钉	SCREW M5 L=5	2
26	10012062	主动轮螺钉	SCREW 11/64-40 L=6	2
27	10011232	螺钉	SCREW M6 L=6	6
28	10000314	上轴带轮螺钉	SCREW M6 L=8	6
29	10000779	上轴带轮组件	SPROCKET A	1
30	10000855	挑线曲柄销	THREAD TAKE UP CRANK SHAFT	1
31	10000845	挑线曲柄销挡圈	THRUST COLLAR D=7 W=8	1
32	10000842	同步齿形带	TIMING BELT	1
33	20000359	惰轮组件	IDLER ASM.	1
34	10003239	惰轮挡圈	RETAINING RING	2
35	10000835	惰轮组件固定螺钉	HINGE SCREW	1
36	10000877	惰轮调节板	IDLER FIXED PLATE	1
37	10000875	惰轮	IDLER PULLEY	1
38	10000899	挡圈	INTERMEDIATE SPROCKET WASHER	1
39	10000876	惰轮螺母	NUT M10	1
40	10049817	上轴风扇	UPPER SHAFT FAN	1
41	10000874	惰轮螺栓	SCREW M10 L=42.5	1
42	10003594	惰轮轴承	BALL BEARING	2
43	10000836	惰轮组件调节螺钉垫圈	WASHER	1
44	10000865	惰轮组件调节螺钉	SCREW M6 L=14	1
45	10000838	连接后块	COUPLING	1
46	10011227	橡胶连接块	RUBBER COUPLING	1

47	10009074	螺钉	SCREW M4 L=4	2
48	10052927	针杆连杆组件	NEEDLE CONNECTING ROD ASSEMBLY	1
49	10060510	挑线杆组件	THREAD TAKE UP ASM.	1

# 4. HOOK DRIVING SHAFT COMPONENTS

下轴部件

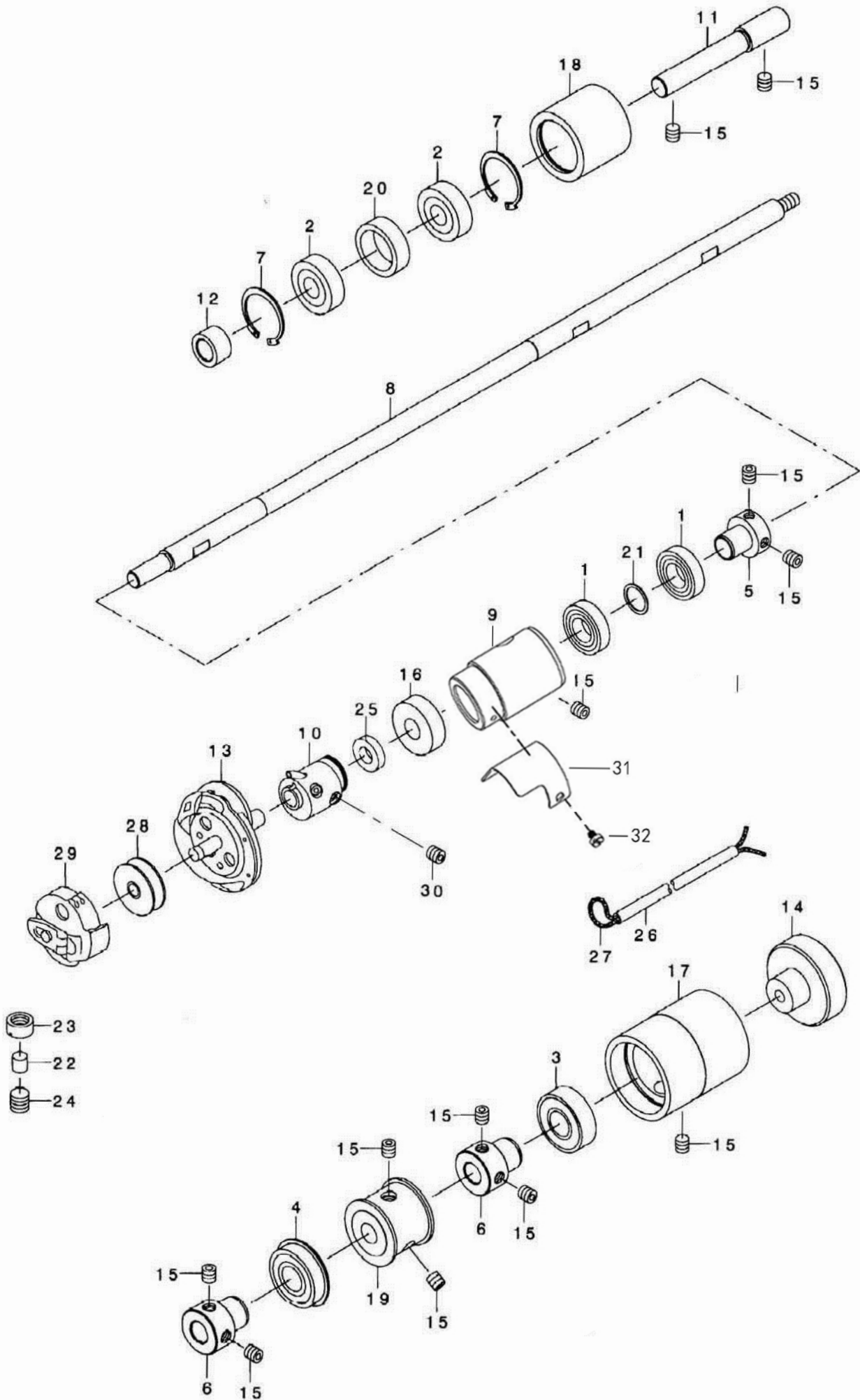



4. 下轴部件				
HOOK DRIVING SHAFT COMPONENTS				
序号 NO.	件号 Part No.	描述	Description	数量
1	10007410	下轴前轴套轴承	BEARING	2
2	10003544	辅助带轮轴承	BALL BEARING	2
3	10003581	下轴后轴套轴承	BEARING	1
4	10003600	下轴中轴套轴承	BEARING	1
5	10000897	下轴前轴套	BEARING_SUPPORT	1
6	10000891	下轴中轴套	BUSH	2
7	10000929	轴承挡圈	RETAINING RING	2
8	10000892	下轴	HOOK_DRIVING_SHAFT	1
9	10000895	下轴前套	HOOK_DRIVING_SHAFT_METAL	1
10	10000902	旋梭供油套组件	HOOK SLEEVE ASM.	1
11	10000898	辅助带轮轴	INTERMEDIATE SPROCKET SHAFT	1
12	10000899	辅助带轮轴挡圈	INTERMEDIATE SPROCKET WASHER	1
13	10033423	旋梭	HOOK COMPL.	1
14	10000775	下轴手轮	CROWN KNOB	1
15	10011232	螺钉	SCREW M6 L=6	12
16	10000883	供油套大毛毡	FELT	1
17	10000893	下轴后轴套大套	BEARING_SUPPORT	1
18	10000900	辅助带轮	SPROCKET_B	1
19	10000774	下轴带轮	SPROCKET_C	1
20	10000901	轴承隔圈	INTERMEDIATE SPROCKET RING	1
21	10000896	下轴前轴套波形垫圈	WASHER	1
22	10000887	油量调节柱	ADJUSTING SHAFT	1
23	10000885	油量调节螺母	ADJUSTING_NUT	1
24	10000884	油量调节螺钉	SCREW M8X8	1
25	10000882	供油套小毛毡	FELT	1
26	10007800	供油套软管	TUBE	1
27	10008069	Φ2油线	OIL WICK	1
28	10000880	梭芯	BOBBIN	1
29	10006759	梭壳	BOBBIN CASE ASM.	1
30	10000881	旋梭供油套螺钉	SCREW	4
31	10061650	挡油板	OIL BAFFLE PLATE	1
32	10009529	螺钉	SCREW M3X3.8	1

# 5. PRESSER & FEED COMPONENTS

压脚、送料部件

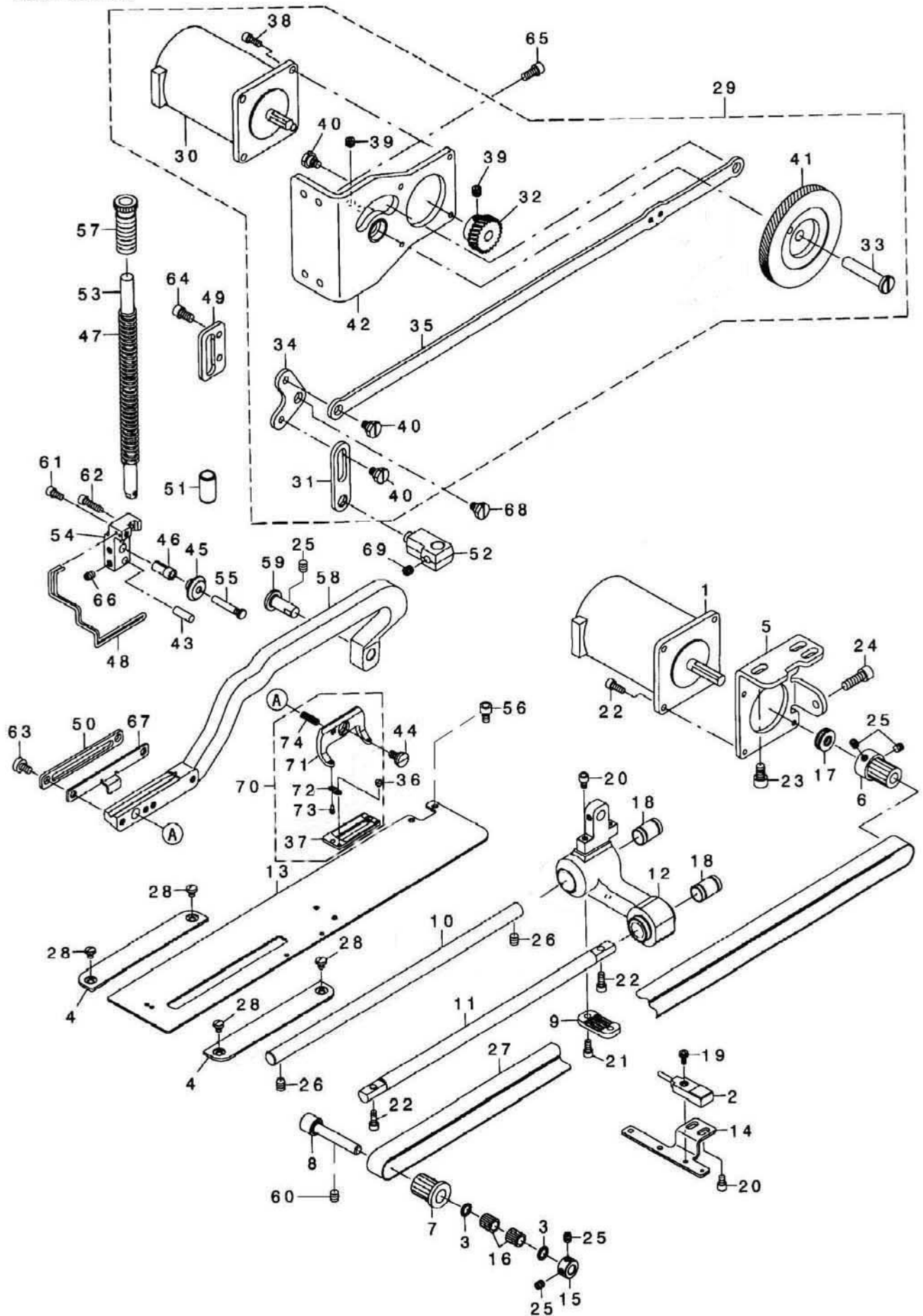

5. 压脚、送料部件				
PRESSER & FEED COMPONENTS				
序号 NO.	件号 Part No.	描述	Description	数量
1	10000796	送料电机	FEED MOTOR ASS'Y	1
2	10049543	送料感应器	FEED SENSOR ASS'Y	1
3	10000004	送料带轮轴承挡片	BEARING SUPPORT	2
4	10000005	左右盖板	THROAT PLATE BASE COVER	2
5	10000955	送料电机固定板	MOTOR BRACKET	1
6	10000970	送布驱动轮组件	PULLEY_B	1
7	10000056	送料带轮组件	PULLEY_C	1
8	10000003	带轮轴	SUPPORT_SHAFT	1
9	10000067	同步带固定块	TIMING BELT HOLDER	1
10	10000000	送料轴	FEED_SHAFT	1
11	10000066	送料导向轴	FEED_GUIDE_SHAFT	1
12	10000945	送料架	FEED_BASE	1
13	10000020	送料板	WORK_CLAMP_CARRIER	1
14	10000957	送料传感器固定板	SENSOR_PLATE	1
15	10000002	送料带轮挡圈	THRUST COLLAR D=7 W=8	1
16	10005747	送料带轮轴承	BEARING	2
17	10000007	单向推力球轴承	BEARING	1
18	10003681	轴承	BEARING	2
19	10000984	送料传感器固定螺钉	SCREW M3X10	1
20	10003399	螺钉	SCREW M4 L=6	4
21	10003399	同步带固定块固定螺钉	SCREW M4 L=8	2
22	10000342	螺钉	SCREW M4 L=10	6
23	10003402	送料电机固定板短螺钉	SCREW M6 L=10	3
24	10010735	送料电机固定板长螺钉	SCREW M6 L=18	1
25	10012162	螺钉	SCREW M5 L=5	5
26	10011232	螺钉	SCREW M6 L=6	2
27	10000001	送料同步带	TIMING BELT	1
28	10000019	左右盖板螺钉	SCREW M4 L=5	4
29	20007581	抬压脚电机组件	ASSY_PBL_GEAR_MODULE	1
30	10041711	抬压脚电机	CLAMP MOTOR ASS'Y	1
31	10000795	抬压脚前曲柄	PBL_FRONT_LINK	1
32	10000794	抬压脚驱动齿轮	PBL_GEAR'S	1
33	10000946	抬压脚齿轮轴	PBL_GEAR_SHAFT	1
34	10000793	抬压脚曲柄	PBL_L_LINK	1
35	10000064	抬压脚长连杆	PBL_LONG_ROD	1
36	10000951	压脚连接螺钉	SCREW 3/32-56 L=1.9	2
37	10000962	抬压脚底板组件	PRESSER	1
38	10000863	抬压脚电机固定螺钉	SCREW M4 L=10	4
39	10000933	抬压脚齿轮轴紧定螺钉	SCREW M6 L=5	5
40	10000261	螺钉	SHOULDER SCREW D8 H3.2	4
41	10000965	抬压脚齿轮	ASSY_PBL_GEAR_L	1
42	10063611	抬压脚电机固定板组件	ASSY_PBL_MOTOR_BASE	1
43	10000939	压杆纵向导销	PIN, SHORT	1
44	10000940	抬压脚轴位螺钉	HINGE SCREW D=7.94 H=2	1
45	10000937	滑动滚子	SLIDE ROLLER	1
46	10000936	滑动滚子导套	COLLAR	1

47	10000949	压杆簧	PBL_COLL_SPRING	1
48	10000950	护指架	PBL_FINGER_GUARD	1
49	10000948	抬压脚导板	PLB_GUIDE	1
50	10000942	压脚纵向导板	PBL_LIFTING_PLATE	1
51	10000934	压杆导套	PBL_METAL	1
52	10000932	抬压脚导块	PBL_POSITION_BRACKET	1
53	10000931	压杆	PBL_PRESSER_BAR	1
54	10000935	压杆连接块	PBL_ROLLER_BASE	1
55	10000938	滑动滚子连接销	PBL_ROLLER_SHAFT	1
56	10003399	送料板固定螺钉	SCREW	2
57	10000930	调压螺钉	PBL_SPRING_REGULATOR	1
58	10000944	抬压脚导架	PBL_WORK_CLAMP_ARM	1
59	10000065	抬压脚导架销	PBL_WORK_CLAMP_ARM_SHAFT	1
60	10009074	带轮轴定位螺钉	SCREW	1
61	10005405	护指架螺钉	SCREW M4 L=9	1
62	10009103	压杆连接块固定螺钉	SCREW M4 L=16	1
63	10002802	压脚纵向导板螺钉	SCREW M5 L=8	2
64	10005490	抬压脚导板固定螺钉	SCREW M5 L=10	4
65	10005139	抬压脚电机固定板螺钉	SCREW M5 L=12	4
66	10012162	滑动滚子导套紧定螺钉	SCREW M5 L=6	2
67	10000941	上切刀复位板	UTT_CLOSE_CAM	1
68	10000261	抬压脚前曲柄轴位螺钉	SHOULDER SCREW D8 H3.2	1
69	10000933	抬压脚导块固定螺钉	SCREW M6 L=5	1
70	10004529	压脚组件	WORK_CLAMP_CHECK HOLDER	1
71	10000008	压脚柄	WORK_CLAMP_CHECK HOLDER	1
72	10000961	抬压脚弹簧片	WORK_CLAMP_CHECK SPRING	2
73	10000068	压脚连接销	WORK_CLAMP_CHECK SPRING SET PI	2
74	10000009	抬压脚弹簧	WORK_CLAMP_CHECK SPRING SPRING	1

# 6.NEEDLE BAR ROCKING COMPONENTS 摆针部件

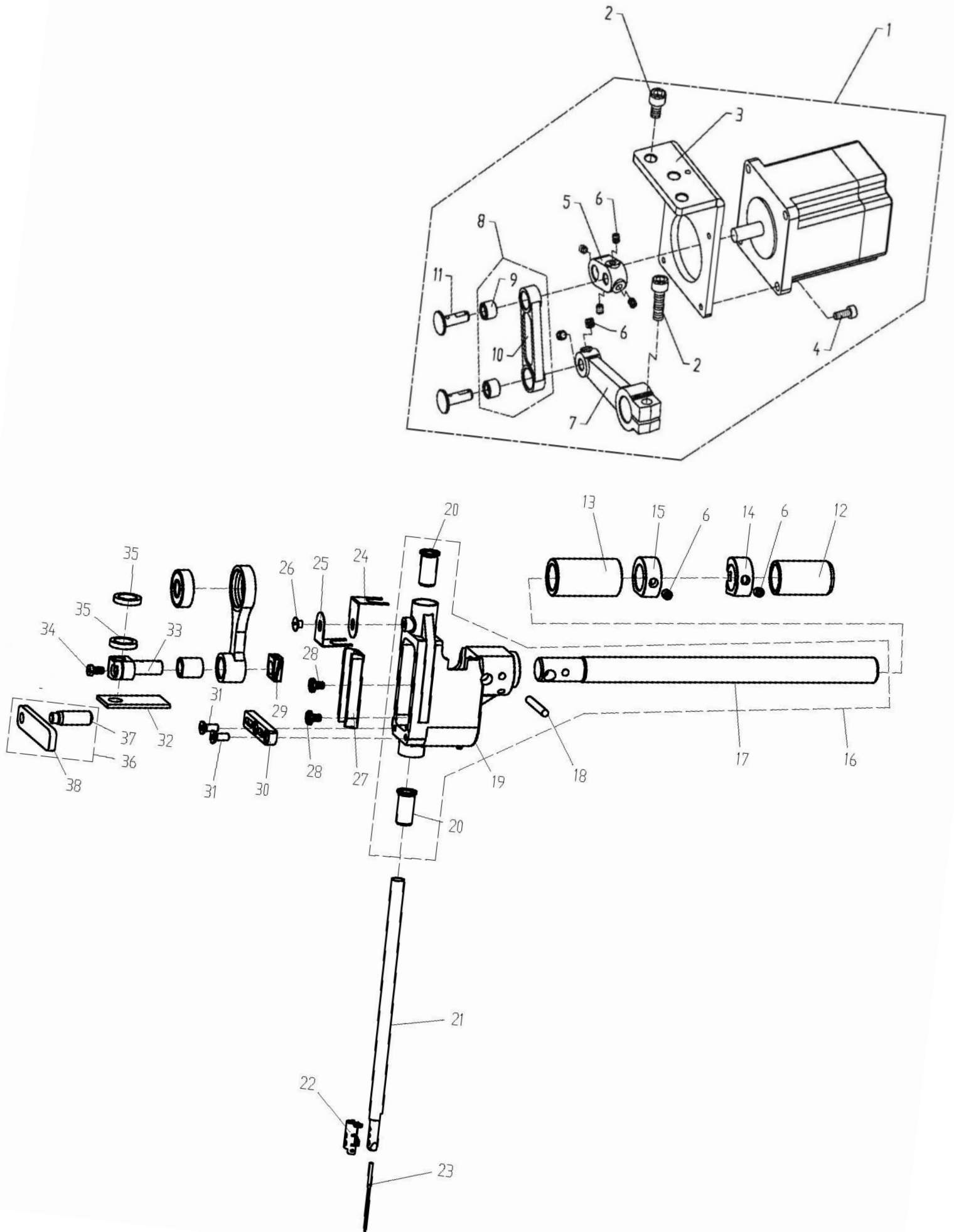

6. 摆针部件				
NEEDLE BAR ROCKING COMPONENTS				
序号 NO.	件号 Part No.	描述	Description	数量
1	20019529	摆针电机安装组件	MOTOR MOUNTING ASSY	1
2	10009008	螺钉	SCREW M6 L=16	4
3	10052936	摆针电机安装板	MOTOR BASE	1
4	10000863	螺钉	SCREW M4 L=12	4
5	10052932	摆针曲柄	MOTOR LEVER	1
6	10012162	螺钉	SCREW M5 L=5	6
7	10000059	摆针大连杆	ZIGZAG LEVER REAR	1
8	10000996	摆针连杆组件	ZIGZAG ROD ASM	1
9	10000983	摆针小连杆套	SHAFT HOLDER LINK BUSH	2
10	10000997	摆针小连杆	ZIGZAG ROD	1
11	10000981	摆针连杆销	JUNCTION SHAFT A	2
12	10000991	摆针轴后套	BUSHING REAR	1
13	10060583	摆针轴前套	BUSHING	1
14	10060584	挡圈	THRUST COLLAR D15 W11	1
15	10040233	针杆架轴挡圈	SCREW M6 L=6	2
16	10060588	针杆摆动架组件	NEEDLE BAR FRAME ASSY	1
17	10052930	摆针轴	BALANCE SHAFT	1
18	10061373	销	PIN	1
19	10060589	针杆摆动架	NEEDLE BAR FRAME	1
20	10000982	针杆套	NEEDLE BAR METAL	1
21	10000953	针杆	NEEDLE BAR	1
22	10000952	针杆线钩	NEEDLE BAR BOBBIN THREAD GUIDE	1
23	10002447	机针	NEEDLE DPX5 #11	1
24	10060582	压板	ROOFING PLATE	1
25	10005197	油毡压板	ROOFING PLATE	1
26	10005050	螺钉	SCREW M4 L=4	1
27	10005263	针杆滑块槽	NEEDLE ROD SLIDE BLOCK	1
28	10005379	螺钉	SCREW M4 L=4.5	2
29	10005326	针杆连接柱滑块	NEEDLE BAR CONNECTION SLIDE	1
30	10060581	针杆架前固定板	NEEDLE BAR FRONT FIXING PLATE	1
31	10060607	螺钉	SCREW	2
32	10060585	下毛毡	ROOF	1
33	10052928	针杆连接柱	NEEDLE BAR CONNECTION	1
34	10000973	螺钉	SCREW	1
35	10000882	供油套小毛毡	ROOF	1
36	10000998	摆针压板组件	MOTO PLATEN ASS	1
37	10001000	摆针压板销	PIN	1
38	10000999	摆针压板	MOTO PLATEN	1

# 7. NEEDLE THREAD TRIMMER COMPONENTS

上切线部件

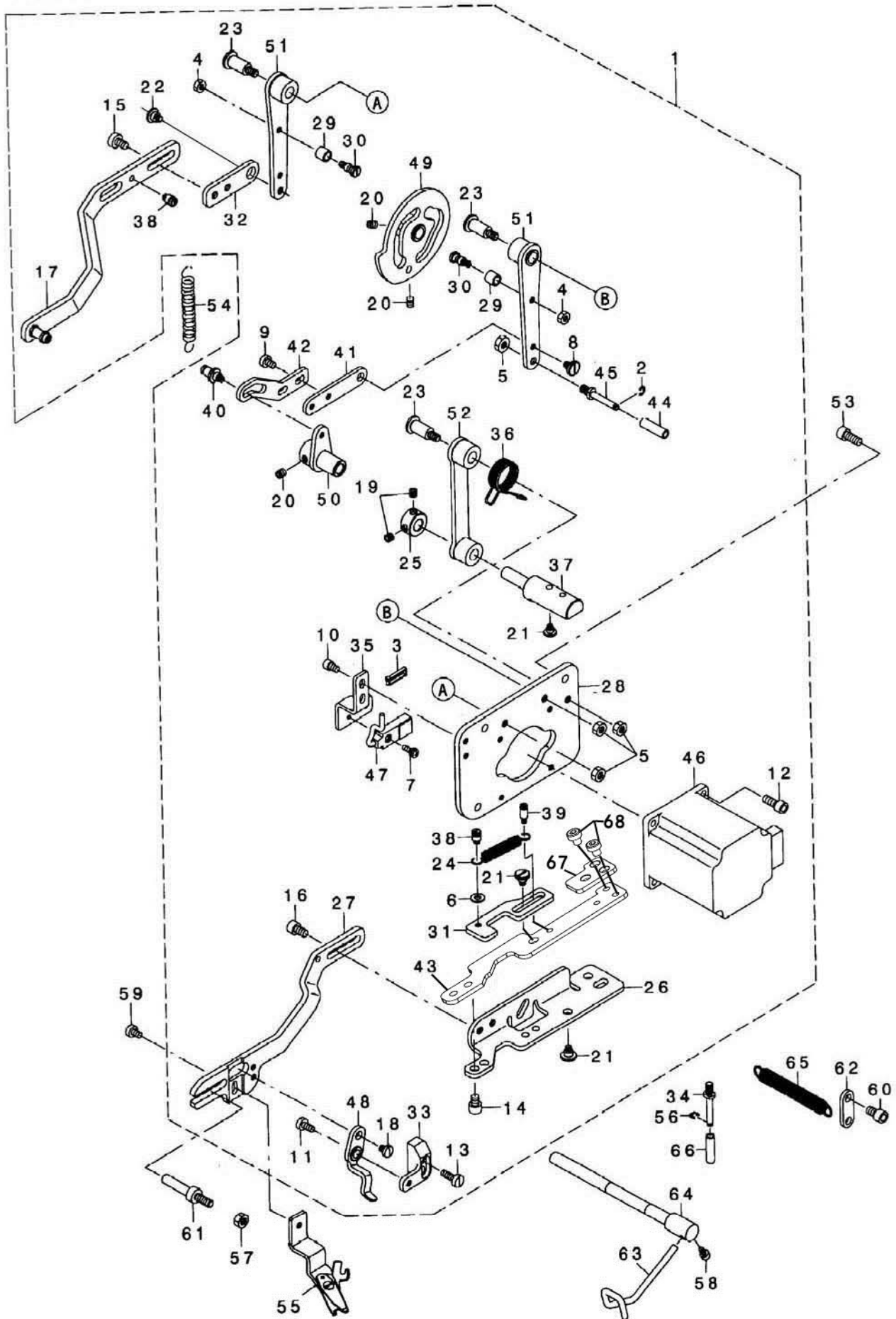

7. 上切线部件				
NEEDLE THREAD TRIMMER COMPONENTS				
序号 NO.	件号 Part No.	描述	Description	数量
1	10003215	上切线电机组件	ASSY UTT MODULE	1
2	10003248	挡圈	E-RING 3	1
3	10003358	线夹	CABLE BAND	1
4	10002076	螺母	NUT M4	2
5	10000994	螺母	NUT M5	4
6	10002765	垫圈	WASHER 4.3X9X0.8	1
7	10000984	螺钉组件	SCREW ASM.	1
8	10003496	轴位螺钉	SHOULDER SCREW D6 H2.6	1
9	10002762	螺钉	SCREW M4 L=6	2
10	10003399	上切线传感器安装螺钉	SCREW M4 L=6	2
11	10003298	螺钉	SCREW M4 L=8	1
12	10003399	上切线电机螺钉	SCREW M4 L=10	4
13	10009037	螺钉	SCREW M4 L=12	2
14	10003881	上切线X板螺钉	HEXAGON SOCKET HEAD SCREW M5X6	2
15	10002802	螺钉	SCREW M5 L=8	2
16	10003442	紧定螺钉	SCREW M5 L=8	2
17	10002497	上切线松线臂组件	ASSY UTT RELEASE ARM B	1
18	10003262	松线杆固定螺钉	SCREW M4 L=5	1
19	10012162	挡圈紧定螺钉	SCREW M5 L=4	2
20	10012162	螺钉	SCREW M5 L=5	4
21	10003256	轴位螺钉	SHOULDER SCREW D6 H3.2	4
22	10002755	轴位螺钉	SHOULDER SCREW D8 H4	1
23	10003266	轴位螺钉	SHOULDER SCREW D8 H15	3
24	10002767	弹簧	SPRING	1
25	10002760	紧圈	THRUST COLLAR D8 W9	1
26	10002469	上切线支承臂A	UTT ARM A	1
27	10002766	上切线悬臂B	UTT ARM A	1
28	10003263	上切刀部件安装板	UTT BASE PLATE	1
29	10000021	上切线凸轮滚柱	UTT CAM ROLLER	2
30	10002803	上切线凸轮滚柱导向螺钉	UTT CAM ROLLER SHAFT	2
31	10002531	止动平板	UTT RATCH PLATE	1
32	10002533	上切线松线臂 A	UTT RELEASE ARM A	1
33	10003297	松线座	UTT RELEASE LEVER BASE	1
34	10003222	轴	UTT Y-DRIVE SHAFT	1
35	10002751	上切线传感器安装板	UTT SENSOR BASE	1
36	10002758	上切线支架扭簧	UTT_SUPPORT_ARM_SPRING	1
37	10003226	上切线支承轴	UTT SUPPORT SHAFT	1
38	10002764	拉簧短螺钉	UTT SUSPENSION SCREW 4	2
39	10002763	拉簧长螺钉	UTT SUSPENSION SCREW 9	1
40	10003495	轴位连接螺钉	UTT SUSPENSION SHOULDER SCREW	1
41	10003441	上切线连接杆A	UTT THREAD PULLING LINK A	1
42	10003494	上切线连接杆B	UTT THREAD PULLING LINK B	1
43	10002566	上切线X板	UTT X-CAM	1
44	10003223	轴套	UTT Y-DRIVE ROLLER	1
45	10003222	轴	UTT Y-DRIVE SHAFT	1
46	10003215	上切线电机	UT TRIM MOTOR ASS'Y	1



47	10049545	上切线感应器	UT TRIM SENSOR ASS'Y	1
48	10002495	松线拨动杆组件	ASSY UTT RELEASE LEVER	1
49	10002568	上切线凸轮组件	ASSY UTT CAM	1
50	10002448	上切线连接臂组件	ASSY UTT THREAD PULLING ARM	1
51	10002496	上切线凸轮导向板组件	ASSY UTT CAM ARM	1
52	10002498	上切线支承臂组件	ASSY UTT SUPPORT ARM	1
53	10014210	上切线部件安装螺钉	SCREW M5 L=12	3
54	10002761	支承板弹簧	BUTTON SUPPORT LEVER SPRING	1
55	10002450	上切刀组件	ASSY UTT TRIMMER	1
56	10003248	挡圈	E-RING 3	1
57	10000994	螺母	NUT M5	1
58	10003399	螺钉	SCREW M4 L=8	1
59	10002762	切刀组件安装螺钉	SCREW M4 L=6	1
60	10003396	紧定螺钉	SCREW M5 L=8	1
61	10003261	导向轴	UTT GUIDE SHAFT	1
62	10003258	弹簧吊钩板	UTT SUSPENSION PLATE	1
63	10003260	上切线拉线杆	UTT THREAD PULLING LEVER	1
64	10003259	拉线轴	UTT THREAD PULLING SHAFT	1
65	10003257	上切线拉簧	UTT TRIMMER CLOSE SPRING	1
66	10003223	轴套	UTT Y-DRIVE ROLLER	1
67	10051478	止动平板定位块	GUIDE PLATE	1
68	10010685	螺钉	SCREW M4 L=6	2

# 8. BOBBIN THREAD TRIMMER COMPONENTS

下切线部件

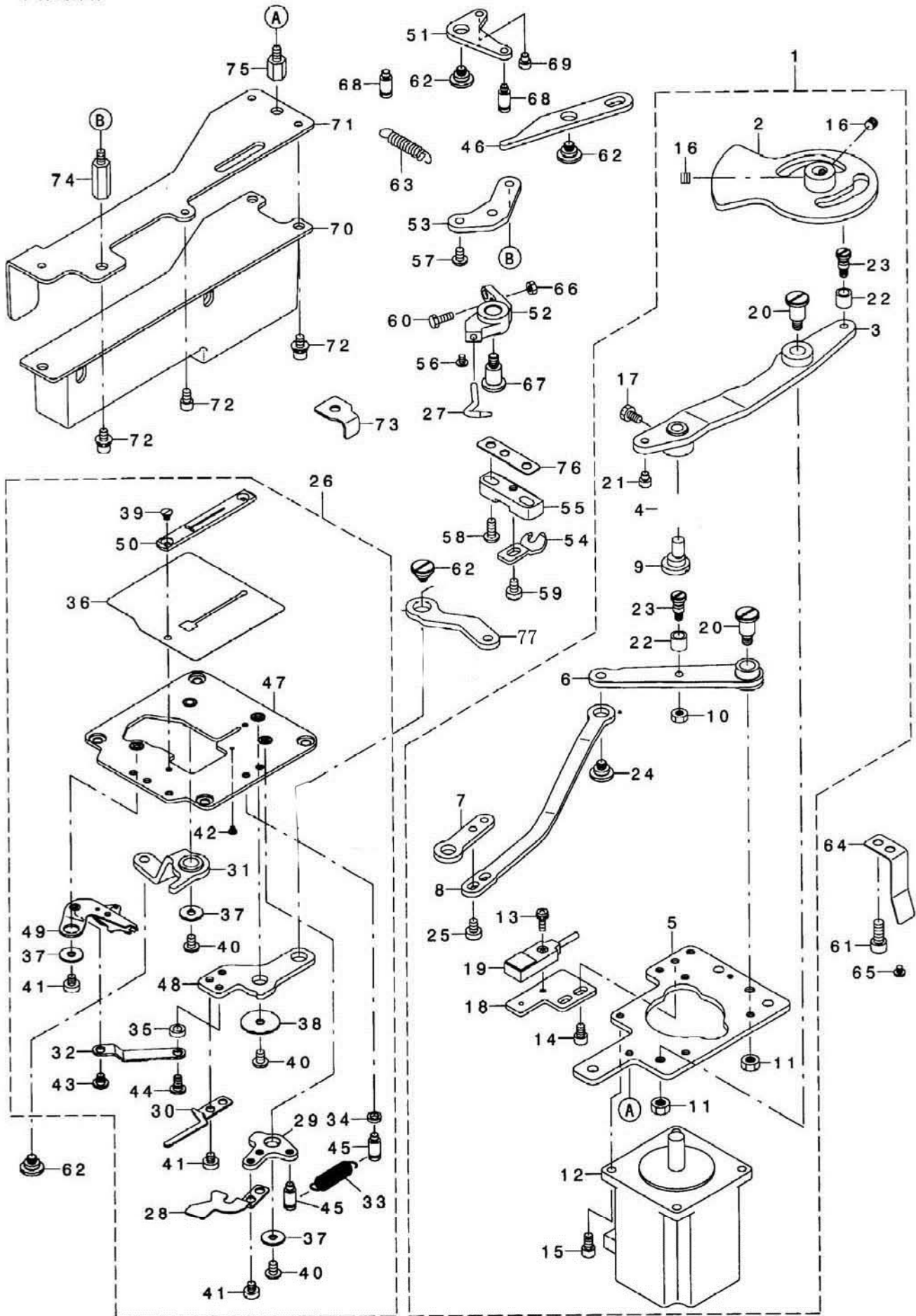

8. 下切线部件				
BOBBIN THREAD TRIMMER COMPONENTS				
序号 NO.	件号 Part No.	描述	Description	数量
1	20007587	下切线电机大组件	BTT_DRIVE_UNIT	1
2	10001143	下切线凸轮组件	ASSY_BTT_DRIVE_CAM	1
3	10001164	下切线主动板组件	ASSY_BTT_DRIVE_LEVER	1
4	10001012	切线传动板	BTT_DRIVE_LINK	1
5	10001009	下切线电机安装板	BTT_DRIVE_UNIT_BASE	1
6	10008447	分刀主动板组件	ASSY_BTT_RELEASE_LEVER	1
7	10001015	分刀传动短杆	BTT_RELEASE_LINK_F	1
8	10001014	分刀传动长杆	BTT_RELEASE_LINK_R	1
9	10001024	切线调节偏心轴	LINK_ROD	1
10	10002076	凸轮滚柱螺钉螺母	NUT_M4	1
11	10001146	分刀主动板组件螺钉螺母	NUT_M5	2
12	10001022	下切线电机	LT_TRIM_MOTOR_ASS'Y	1
13	10000984	下切线传感器螺钉组件	SCREW_M3_X_10	1
14	10010685	传感器安装板螺钉	SCREW_M4_L=6	2
15	10001010	下切线电机螺钉	SCREW_M4_L=8	4
16	10012162	下切线凸轮组件螺钉	SCREW_M5_L=4	2
17	10001013	切线调节偏心轴螺钉	HEXAGONAL_BOLY	1
18	10001021	传感器安装板	SENSOR_FITTING_PLATE_BT	1
19	10049546	下切线传感器	LT_TRIM_SENSOR_ASS'Y	1
20	10001029	螺钉	SHOULDER_SCREW_D8_H10	2
21	10001124	挡线驱动板主动螺钉	STOPPER_PIN	1
22	10000021	凸轮滚柱	UTT_CAM_ROLLER	2
23	10000919	凸轮滚柱螺钉	UTT_CAM_ROLLER_SHAFT	2
24	10001023	分刀传动长杆螺钉	SHOULDER_SCREW_D8_H2.9	1
25	10010554	分刀传动连接螺钉	SCREW_M3_L=6	2
26	10025945	下切线大组件	THROAT_PLATE_BASE_COMPL	1
27	10003487	挡线钩	PICKER	1
28	10000915	上拨线板	BT_CLAMP	1
29	10000910	上拨线板座	BT_CLAMP_LEVER	1
30	10001120	下拨线板	BT_PULLER	1
31	10001126	分刀板组件	ASSY_BT_RELEASE_ARM	1
32	10000022	下切线组件驱动板	BT_TRIMMER_LINK	1
33	10000918	上拨线板拉簧	SPRING	1
34	10000916	上拨线板拉簧紧定螺钉	WASHER	1
35	10000070	下切线组件驱动板长螺钉垫	WASHER	1
36	10001123	针板垫	OIL_SHIELD	1
37	10001017	垫片	PLAIN_WASHER_4.3X12X1	3
38	10001121	下切线板座螺钉垫片	WASHER_4.5X20X1	1
39	10001145	针板螺钉	SCREW_M3_L=4	2
40	10001051	螺钉	SCREW	3
41	10000041	下切刀组件螺钉	SCREW_M4_L=4	9
42	10000917	上拨线定位螺钉	HINGE_SCREW	1
43	10000071	下切线组件驱动板短螺钉	SHOULDER_SCREW_D5_H1.6	1
44	10001144	下切线组件驱动板长螺钉	SHOULDER_SCREW_D5_H1.6	1
45	10001053	上拨线板拉簧动螺钉	SUSPENSION_SCREW	2
46	10001016	挡线驱动板	PICKER_ACTUATING_LEVER	1

47	10001155	针板座组件	ASSY_THROAT_PLATE_BASE	1
48	10000072	下切线板座	BTT_LEVER	1
49	10001127	下切刀组件	ASSY_BTT_LOWER	1
50	10000074	针板	THROAT_PLATE(K)	1
51	10001052	挡线传动板	PICKER_ACTUATING_L_LINK	1
52	10001028	挡线连接块	PICKER_BASE	1
53	10001026	挡线连接块安装板	PICKER_BASE_FITTING_PLATE	1
54	10000912	旋梭定位钩	STOPPER_A	1
55	10000913	旋梭定位钩座	BOBBIN_CASE_POSITIONING_PLATE	1
56	10000040	挡线钩螺钉	SCREW_M3_L=4	1
57	10001027	挡线连接块安装板螺钉	SCREW_M4_L=5	1
58	10009104	旋梭定位钩座螺钉	SCREW_M4_L=10	2
59	10010554	旋梭定位钩螺钉	SCREW_M4_L=6	1
60	10001025	挡线连接块复位螺钉	SCREW_M4_L=12	1
61	10001010	下切线电机安装板螺钉	SCREW_M5_L=8	3
62	10001125	螺钉	SHOULDER_SCREW_D8_H2.9	4
63	10000918	上拨线板拉簧	SPRING	1
64	10001020	安全开关挡板	SAFETY_SWITCH_PRESSING_PLATE	1
65	10009529	安全开关挡板螺钉	SCREW	1
66	10002076	挡线连接块复位螺钉螺母	NUT_M4	1
67	10001029	挡线连接块螺钉	SHOULDER_SCREW_D8_H10	1
68	10001053	挡线传动板长螺钉	SUSPENSION_SCREW	2
69	10001018	挡线传动板短螺钉	STOPPER_PIN	1
70	10001137	油盒组件	OIL_TANK_ASM.	1
71	10000073	油盒安装板	OIL_TANK_PLATE	1
72	10001135	油盒组件螺钉	SCREW	6
73	10000911	挡线连接块挡板	PICKER_BASE_STOPPER	1
74	10000039	油盒安装长螺钉	STUD	1
75	10001011	油盒安装短螺钉	STUD	1
76	10000914	旋梭定位钩座垫	BTT_SPACER	1
77	10001012	切线传动板	TANGENTIAL_DRIVE_PLATE	1

# 9.CLOTH CUTTING KNIFE COMPONENTS

切布刀部件

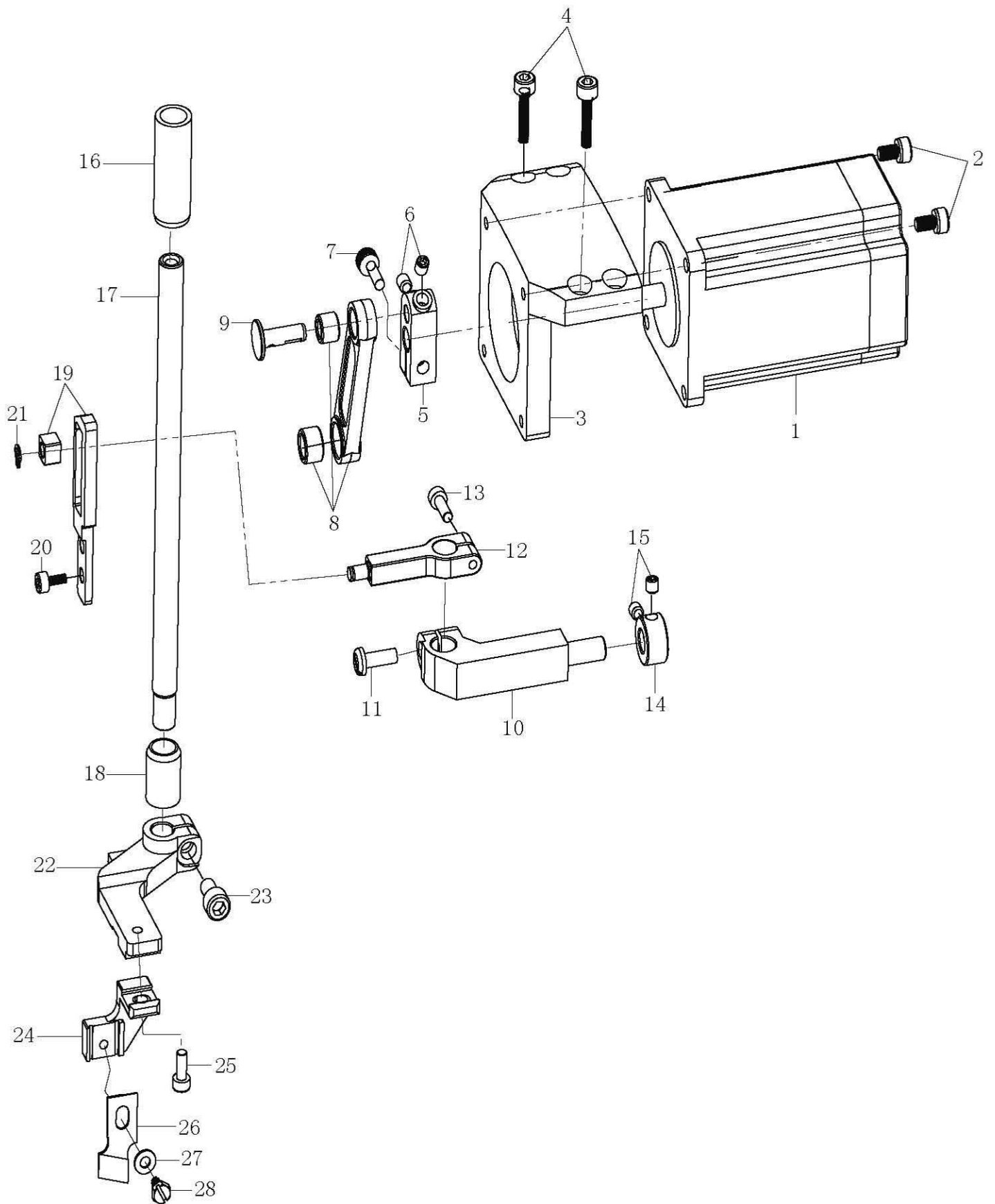

9. 切布刀部件				
CLOTH CUTTING KNIFE COMPONENTS				
序号 NO.	件号 Part No.	描述	Description	数量
1	10041709	切布刀闭环电机	KNIFE MOTOR ASS'Y	1
2	10009103	电机固定螺钉	SCREW M4 L=16	4
3	10039445	电机安装架	MOTOR BRACKET	1
4	10000860	电机安装架固定螺钉	SCREW M5 L=12	4
5	10039439	电机驱动块	MOTOR DRIVE BLOCK	1
6	10012162	螺钉	SCREW M5 L=5	2
7	10005139	驱动块固定螺钉	SCREW M5 L=12	1
8	10039441	电机驱动连杆组件	CONNECTING ROD ASSEMBLY	1
9	10000981	连杆曲柄销	BELL CRANK SHAFT	1
10	10039440	切刀轴连接柱	KNIFE CONNECTING SHAFT	1
11	10001159	连接柱螺钉	SCREW	1
12	10051906	切刀轴导向柱	CUTTER SHAFT GUIDE POST	1
13	10000863	螺钉	SCREW M4 L=12	1
14	10002760	紧圈	SHRINK-RING	1
15	10012162	螺钉	SCREW M=5 L=5	2
16	10001185	切布刀竖轴上套	KNIFE BAR BUSH	1
17	10001169	切布刀竖轴	KNIFE BAR	1
18	10001181	切布刀竖轴下套	KNIFE BAR LOWER BUSHING	1
19	10051994	切布刀导向滑块组件	RAG KNIFE GUIDE SLIDER ASSEMBLY	1
20	10003399	导向板螺钉	SCREW M4 L=8	2
21	10009668	5挡圈	BEAD FLANGE	1
22	10001180	切布刀驱动架	KNIFE BAR BASE	1
23	10011824	切布刀驱动架螺钉	SCREW M6 L=12	1
24	10001160	切布刀架	KNIFE FITTING BASE	1
25	10005139	切布刀架螺钉	SCREW	1
26	10001086	切布刀	KNIFE	1
27	10002765	切布刀螺钉垫片	WASHER 4.3X9X0.8	1
28	10001189	切布刀螺钉	HEXAGONAL BOLT	1

# 10. ACCESSORIE PART COMPONENTS

附件

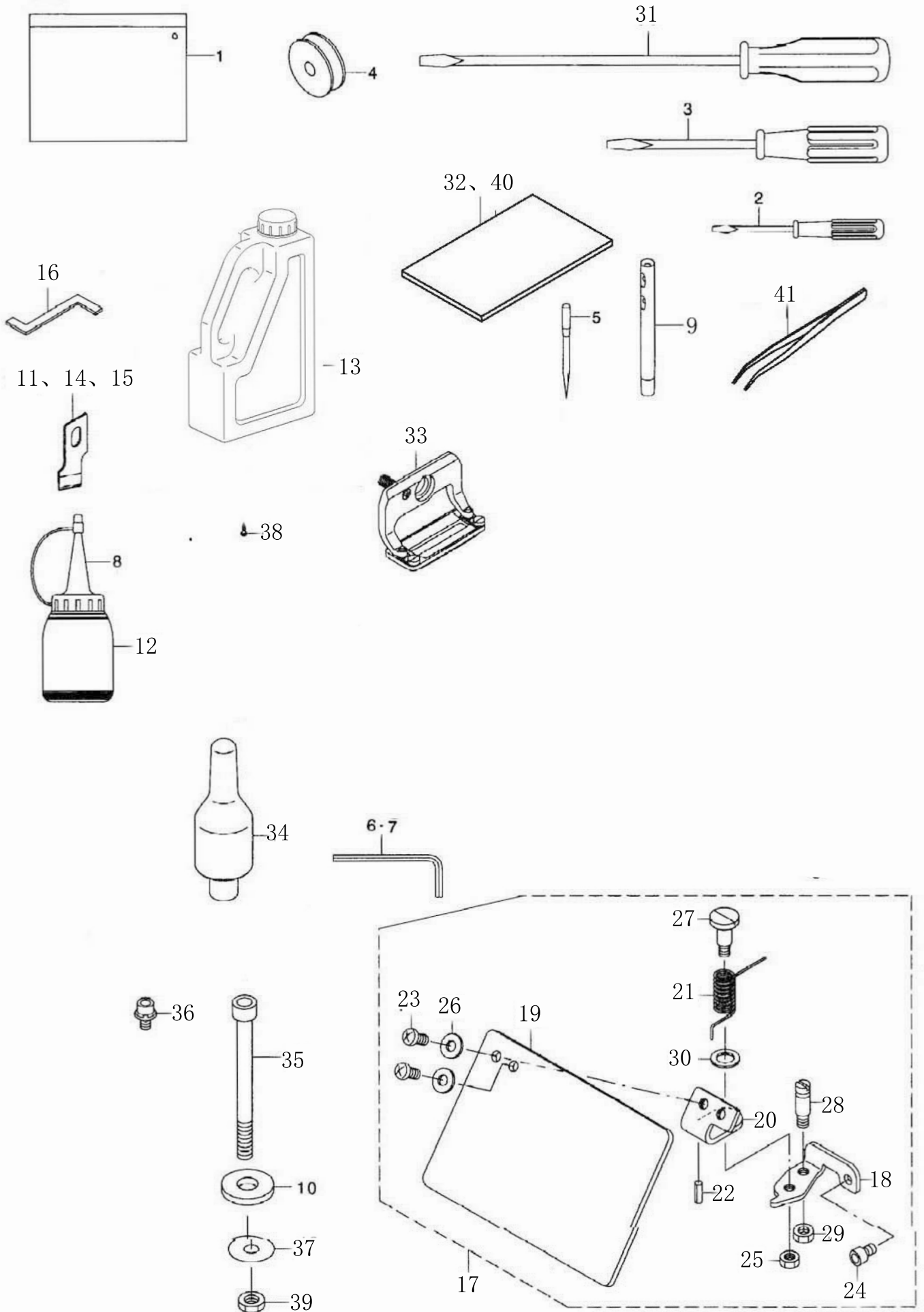

10. 附件				
ACCESSORIES PART COMPONENTS				
序号 NO.	件号 Part No.	描述	Description	数量
1	10001177	机头罩☆	ACCESSORIE BAG	1
2	10013185	小螺丝刀☆	SCREW DRIVER, SMALL	1
3	10010995	中螺丝刀☆	SCREW DRIVER, MIDDLE	1
4	10000880	梭心	BOBBIN	3
5	10002447	机针☆	EEEDLE DPX5 #11~#14	1
6	10009685	内六角扳手	HEXAGONAL WRENCH KEY	1
7	10009689	内六角扳手	HEXAGONAL WRENCH KEY	1
8	10006373	小油壶帽	OILER CAP	1
9	10000167	两眼过线柱	THREAD GUIDE BAR	1
10	10003357	底座锁紧螺钉橡胶垫片	RUBBER CUSHION(B)	4
11	10001192	切布刀	KNIFE 1	1
12	10013294	小油壶	OILER	1
13	10004455	油箱	DEFRIX OIL NO. 1(600CC)	1
14	10001093	切布刀	KNIFE 5/8	1
15	10001092	切布刀	KNIFE 3/8	1
16	10001174	高度块	HOOK TIMING GAUGE, K	1
17	20000415	眼睛防护罩组件	ASSY SAFETY PLATE	1
18	10001338	安全板座	SAFETY PLATE FITTING BASE	2
19	10011636	安全板	SAFETY PLATE	1
20	10001339	安全板组件	SAFETY PLATE INSTALLING PLATE	1
21	10011678	安全板弹簧	SAFETY PLATE RETURN SPRING	1
22	10002880	弹性圆柱销	SPRING PIN 2X6	2
23	10011570	安全板螺钉	SCREW 11/64-40 L=7	2
24	10003399	安全板座螺钉	SCREW M4 L=6	1
25	10000100	轴位螺钉螺母	NUT 11/64-40	2
26	10011680	安全板螺钉垫片	WASHER 4. 5X10X0. 8	1
27	10011677	安全板轴位螺钉	HINGE SCREW D=6 H=10. 2	1
28	10011633	弹簧复位销	TENSION SPRING RACK B	1
29	10011682	复位销螺母	NUT 3/16-28	1
30	10001289	轴位螺钉垫片	WASHER 7. 4X10X0. 8	1
31	10010994	大螺丝刀☆	SCREW DRIVER, LARGE	1
32	10050264	零件手册说明书☆	PARTS MANUAL	1
33	10006197	压脚组件	WORK CLAMP CHECK HOLDER	1
34	10011749	机头支承杆	HEAD SUPPORT BAR	4
35	10003832	底板锁紧螺钉	HEXAGON BOLT	4
36	10003875	接地线螺钉组件	BOLT	1
37	10003395	底座锁紧螺钉垫片	WASHER 6. 1X18. 5X2	4
38	10008323	踏脚开关安装木螺钉	WOOD SCREW D=4. 8 L=20	2
39	10003078	底座锁紧螺母	NUT M6	8
40	10037832	电控说明书☆	ELECTRIC CONTROL SPECIFICATION	1
41	10004247	镊子组件	TWEEZERS COMPONENT	1



# 11. THREAD STAND COMPONENTS

过线架部件

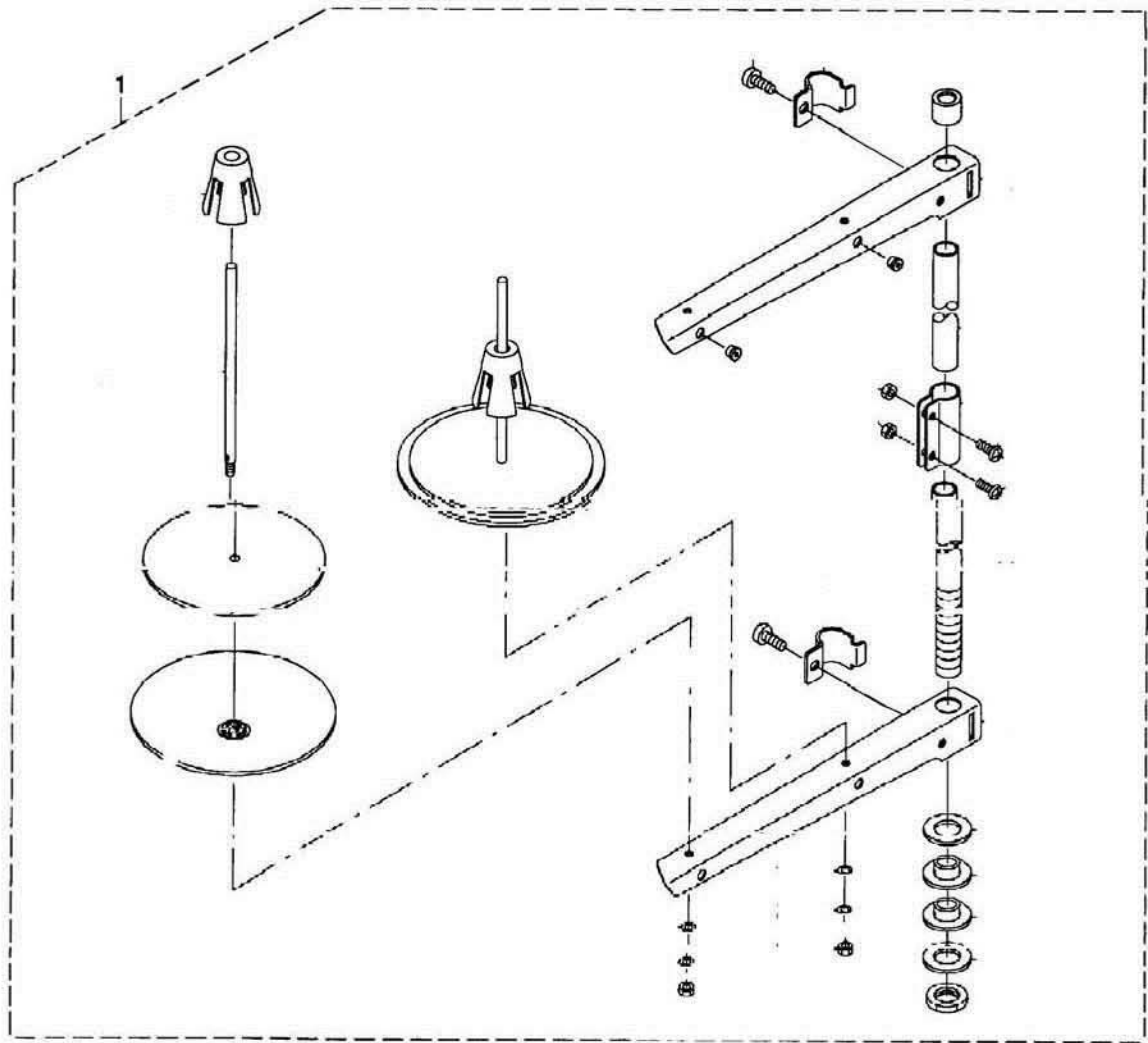

序号	件号	描述	DESCRIPTION	数量
1	10007130	过线架组件	THREAD STAND ASM.	1

12. CONTROL BOX COMPONENTS

电控部件

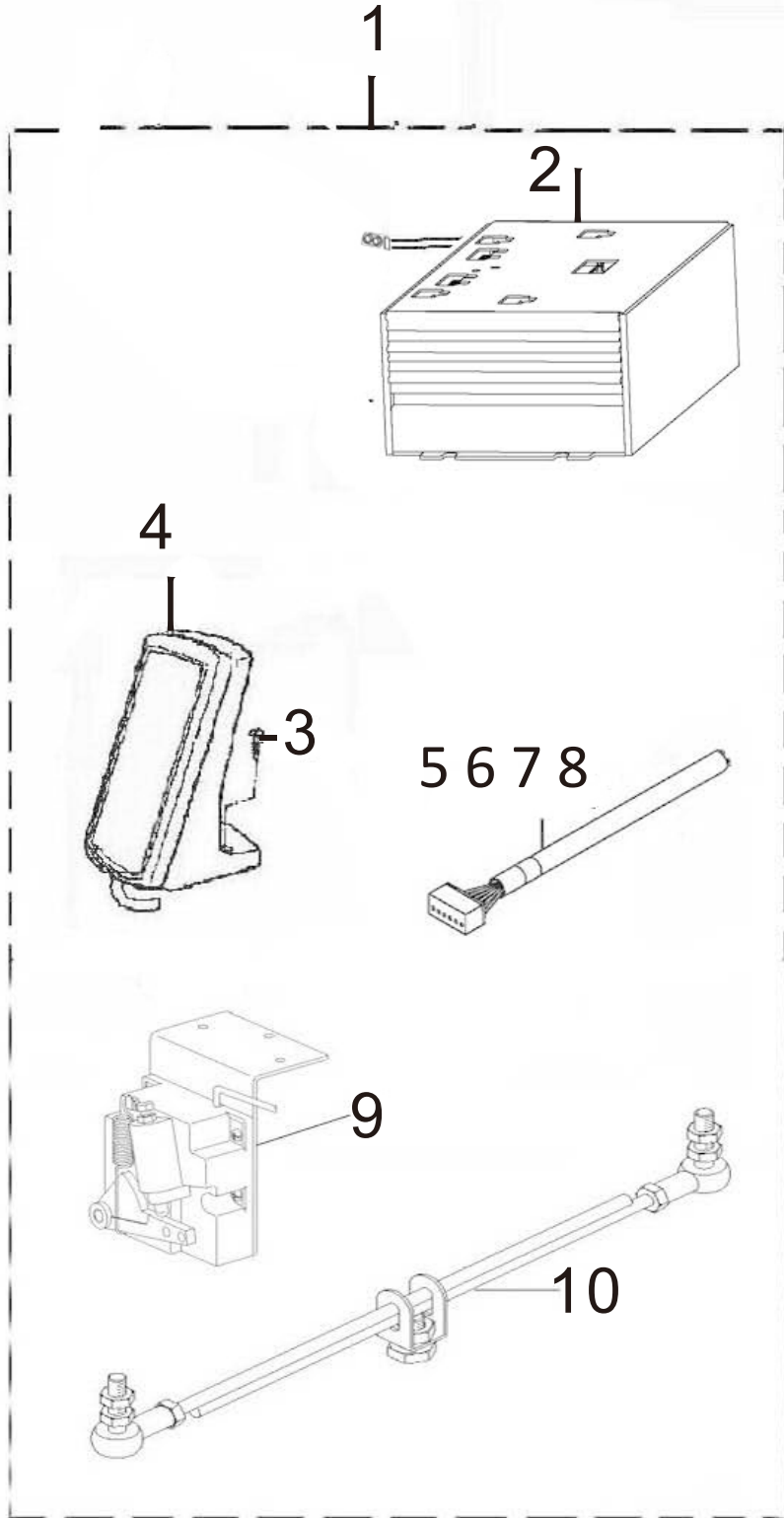

12. CONTROL BOX COMPONENTS			
NO.	Part No.	Description	Q-ty
1	10053754	CONTROL BOX ASSEMBLY	1
2	10001298	POWER SWITCH	1
3	10008323	SCREW	2
4	10053755	OPERATION BOX	1
5	10048837	L725 CABLE	1
6	10048838	L724-1 CABLE	1
7	10025146	L524-1 CABLE	1
8	10049550	L437 DISCONNECTION DETECTION CABLE	1
9	10024990	PEDAL UNIT ASM	1
10	10024458	PEDAL CONTROL ROD ASM	1

\* check the model of the machine with the supplier Different years of manufacture may have different details.

## Special parts list

Name	Item number
9.5mm knife	10001092
12.7mm knife	10001086
15.9mm knife	10001093
25.4mm knife	10001192
5×35 Presser foot	10006179
5×70 Presser foot	10028680
5×100 Presser foot	10028685
K type small needle eye needle plate	10061804

Part	Standard S	Knitting K	Feature L
Presser foot assembly	10004529	10062461	10049886
Needle plate	10000074	10061804	10000074
Transport plate	10000020	10000020	10007084
Presser foot lifter	10000944	10000944	10007086
Presser foot vertical guide	10000942	10000942	10007085
Upper cutter reset plate	10000941	10000941	10007079